

Алматы (7273)495-231
Ангарск (3955)60-70-56
Архангельск (8182)63-90-72
Астрахань (8512)99-46-04
Барнаул (3852)73-04-60
Белгород (4722)40-23-64
Благовещенск (4162)22-76-07
Брянск (4832)59-03-52
Владивосток (423)249-28-31
Владикавказ (8672)28-90-48
Владимир (4922)49-43-18
Волгоград (844)278-03-48
Вологда (8172)26-41-59
Воронеж (473)204-51-73
Екатеринбург (343)384-55-89

Иваново (4932)77-34-06
Ижевск (3412)26-03-58
Иркутск (395)279-98-46
Казань (843)206-01-48
Калининград (4012)72-03-81
Калуга (4842)92-23-67
Кемерово (3842)65-04-62
Киров (8332)68-02-04
Коломна (4966)23-41-49
Кострома (4942)77-07-48
Краснодар (861)203-40-90
Красноярск (391)204-63-61
Курск (4712)77-13-04
Курган (3522)50-90-47
Липецк (4742)52-20-81

Магнитогорск (3519)55-03-13
Москва (495)268-04-70
Мурманск (8152)59-64-93
Набережные Челны (8552)20-53-41
Нижний Новгород (831)429-08-12
Новокузнецк (3843)20-46-81
Ноябрьск (3496)41-32-12
Новосибирск (383)227-86-73
Омск (3812)21-46-40
Орел (4862)44-53-42
Оренбург (3532)37-68-04
Пенза (8412)22-31-16
Петрозаводск (8142)55-98-37
Псков (8112)59-10-37
Пермь (342)205-81-47

Ростов-на-Дону (863)308-18-15
Рязань (4912)46-61-64
Самара (846)206-03-16
Санкт-Петербург (812)309-46-40
Саратов (845)249-38-78
Севастополь (8692)22-31-93
Саранск (8342)22-96-24
Симферополь (3652)67-13-56
Смоленск (4812)29-41-54
Сочи (862)225-72-31
Ставрополь (8652)20-65-13
Сургут (3462)77-98-35
Сыктывкар (8212)25-95-17
Тамбов (4752)50-40-97
Тверь (4822)63-31-35

Тольятти (8482)63-91-07
Томск (3822)98-41-53
Тула (4872)33-79-87
Тюмень (3452)66-21-18
Ульяновск (8422)24-23-59
Улан-Удэ (3012)59-97-51
Уфа (347)229-48-12
Хабаровск (4212)92-98-04
Ханты-Мансийск (3462)28-53-07
Челябинск (351)202-03-61
Череповец (8202)49-02-64
Чита (3022)38-34-83
Якутск (4112)23-90-97
Ярославль (4852)69-52-93

Россия +7(495)268-04-70

Казахстан +7(7172)727-132

Киргизия +996(312)96-26-47

<https://comeup.nt-rt.ru/> || cpb@nt-rt.ru

PRODUCT GUIDE

Defense & Security Winch • Automotive Winch
Powersports Winch • Industrial Winch • Hydraulic Hoist

Getting you through since 1975



**COMEUP
WINCH**



CONTENTS

- Defense & Security Winch 05-08
- Automotive Winch 09-43
- Powersports Winch 44-49
- Industrial Winch 50-73
- Hydraulic Hoist 74-76



COMEUP Milestones

1975

• Aug. Founded Chuan Phang Ent.Co. Ltd.



1992

• Xizhi HQ & Main Factory



1996

• Contracted with TTK in Japan for the production of Keeper



1998

• CWL series winches were awarded the Symbol of Excellence in Taiwan

2000

• Awarded DNV ISO9001 International Quality Certificate

2001

• All DC winches have had CE Marking approved
• Contracted with Furukawa Co., Ltd in Japan for the production of heavy duty hoist



2002

• DV Series self-recovery winch awarded the Symbol of Excellence in Taiwan



2003

• The CBS (Cone Brake Structure) brake device for winches filed patents in U.S.A., U.K., Germany, Taiwan, and China, etc.



2004

• Company name changed to Comeup Industries Inc.

2006

• Contracted with Planeta-Hebetechnik GmbH in Germany for the production of compact winch

2007

• DV-9000I winch at the North Pole



2009

• New hydraulic winches had SAE J706 certificate from TÜV
• Certified by TÜV NORD according to ISO 9001:2008
• DS-9.5i winch at the South Pole



2010

- Announced the brand's new logo
- DV-9i winch at the erupting volcano Eyjafjallajökull
- Seal 9.5i winch at the South Pole

COMEUP



2011

- Seal 9.5i winch at the South Pole



2012

- Set up the USA branch office
- Seal 9.5sl winch at the South Pole



2013

- Seal 9.5rsi winch at the South Pole
- Seal 9.5i winch in RFC Malaysia



2014

- Seal 9.5rsi winch at the South Pole
- Blazer competition winch in RFC Malaysia
- IDB (Intelligence Dashboard) patented for New Seal Gen2 version



2015

- Competition winch (Blazer) in RFC India
- Seal Gen2 9.5i winch in RFC Malaysia



2016

- Seal Gen2 16.5rs was awarded the Global Media Awards Winner in SEMA
- Competition winch (Blazer) in RFC India, RFC & Rainforest Trophy Malaysia
- New headquarter & factory in Ruifang



2017

- Competition winch (Blazer) in RFC & Rainforest Trophy Malaysia
- MadX winch in Mahindra Adventure Great Escape India
- Seal Gen2 9.5i/sl/rsi winches were awarded the Symbol of Excellence in Taiwan



2018

- Certified by TÜV NORD according to ISO 9001:2015



2019

- UW-5000sl utility winch was awarded the Symbol of Excellence in Taiwan



2020

- COMEUP TEAM at Arctic Ocean
- COMEUP Industries Inc. awarded the 23rd Rising Star Award



2021

- Blazer M3/M2 competition winch was awarded the Symbol of Excellence in Taiwan



WE WORK FOR OUR CUSTOMERS. NOT AN EQUITY FIRM.



Unlike most other winch companies, COMEUP is a family-run operation obsessed with the importance of detail appreciated by customers around the world. What we make, must be the best. What we do must benefit our customers.

COMEUP Vertical Factory and Headquarters : Quality From Within

Started over four decades ago, COMEUP instituted the Flexible Manufacturing System in conjunction with Mori Seiki Japan. This emphasized controls at each step in the manufacturing process to assure high quality of each product component.

The COMEUP approach to process and quality thinking and execution is evident in the new, multi-floor factory. This vertical factory design increases control, efficiency and lines of communication compared to the typical single floor sprawl. The result is employee exposure to all product process stages and an engagement in quality output.

This is especially important with critical components, such as motors. Unlike other brands, COMEUP designs and manufactures their motors in their own manufacturing facility. This makes for perfect integration with the gear train and the COMEUP patented Cone Brake Structure. And COMEUP makes 70% of their components in-house.

Products and Safety Certified By Third Parties

COMEUP has TÜV Nord ISO 9001:2015 certification for quality management. COMEUP also has the CE marking for product safety requirements. Many products meet the IP68 International Protection marking protected from immersion in water with depth of more than 1 meter; ATV/UTV winches have EEC Directive 97/24/EC Chapter 8 from ROW-Netherlands and hydraulic winches are compliant with SAE J706 per TÜV Rheinland.



The Companies We Keep

COMEUP products are distributed in more than 60 countries on 5 continents. We provide standard products as well as products designed specifically for OEM applications. We provide OEM products to companies such as Toyo Koki KK Japan, Furukawa Co Ltd Japan, Planeta Hebetchnik GmbH in Germany and Miller Industries - Offroaders around the world rely on our standard recovery winch products to get back home.

Reliability. It Matters To Us. It Matters To Your Customers

COMEUP has a lifetime warranty for mechanical components and a one-year warranty for electrical components, from the date of the user's purchase.



The COMEUP internal engineering team generates their own IP



COMEUP produces the motors for their winch systems



Each and every COMEUP winch is tested before it is boxed and shipped



Skilled operators using advanced equipment—such as single-operation, complex mill-turn centers and CNC vertical machining—consistently produce components with precise tolerances.



川方金業

DEFENSE & SECURITY WINCH

EXTREME PERFORMANCE

Incredible, Submersible, Sealed, Waterproof, Defense & Security Winches

COMEUP premium quality winches have been to the North Pole, the South Pole and nearly everywhere in between. Defense & Security winches feature corrosion resistance exceeding 720 hrs. and the contactor & motor are potted providing complete protection. Double lip and spring seal at drum housings and rubber seals at motor and gear housing joints for an IP68 waterproof and dustproof rating. With line pull capacities up to 22,000 lb and a limited lifetime warranty the Walrus Series from COMEUP will exceed your performance and durability expectations.

▶ Walrus Series 18,000 - 22,000 lb



- ▶ Limited Lifetime Warranty for Mechanical Components.
- ▶ Three (3) Years Warranty for Electrical Components.

WALRUS SERIES

18,000 - 22,000 lb pulling capacity



- 1 Fully Sealed Contactor & Motor**
Potted contactor and motor provide complete protection from water penetration and allow dependable operation in up to 1.8 meters of water.
- 2 Military Connector**
Industrial duty remote control with twist-on connector to provide total protection from water.
- 3 Aluminum Alloy Housings**
Tough aluminum alloy die cast housings can withstand forces greater than 2 times the winch's rated capacity.
- 4 Double Lip and Spring Seal at Drum Housings**
Rubber seals at motor and gear housing joints for superior water protection.
- 5 Rapid Wire Rope Payout & Clutch Reposition**
An ergonomic T-handle positively engages the free spool clutch through multiple evenly spaced locking holes. Clutch handle can be repositioned at 90 degree increments to allow easy access in various winch mounting positions.
- 6 Hardened Steel 3-stage Planetary Gear Train**
Rugged and quiet planetary gears for maximum mechanical efficiency.
- 7 Automatic, Full Load Cone Brake Structure (CBS)**
U.S. Germany, U.K. France, etc patented mechanical cone brake mounted outside the drum expedites heat dispersion and holds the full load without slippage.
- 8 Standard Accessories**
Comes with cable tensioner and roller fairlead as standard.
- 9 Protective Thermal Sensor LED**
Waterproof remote control with thermometric LED indicator to alert the operator if the motor begins to overheat, protecting the winch from damage.

Corrosion resistance 720 hrs

Qualified IP 68 (Ingress Protection Rating)

- Walrus winches comply with the requirement and acceptance condition of IEC 60529 Edition 2.1:2001 ingress of protection provided by Enclosure-IP68.
- Meets international standards of CE Machinery Directive 2006/42/EC, CE Electromagnetic Compatibility Directive 2014/30/EU, and SAE J706 surface vehicle standard 2003-08 rev.



Walrus 22.0

22,000 LB Defense & Security Winch

PN 282210 24V (with wire rope, roller fairlead, cable tensioner, remote control)



SPECIFICATIONS :

- Rated line pull : 9,980 kg (22,000 lb) single line
- Motor : 5,220 w / 7.0 hp, 24V series wound w/thermal protection switch
- Gear train & ratio : 3-stage planetary 343:1
- Clutch (freespooling) : Rotating ring gear
- Brake (outside the drum) : Automatic, full load CBS (Cone Brake Structure)
- Winch construction : Aluminum die cast housings with steel drum
- Drum size : 102 x 254 mm (4" x 10")
- Control : Waterproof remote with thermometric indicator LED w/ 5 m (17') cord
- Rope : 6 x 29 - IWRC (Breaking strength 126.4 kN), 12.7 mm x 25 m (1/2" x 82')
- Recommended battery : 650 CCA minimum for winching
- Battery lead : 1.8 m (6') 2 gauge battery lead
- Mounting bolt pattern : 304 x 114.3 mm (12" x 4.5") ; 304 x 165 mm (12" x 6.5")
- Mounting : Foot forward mounting only
- Winch weight (Including rope) : 80 kg / 176.4 lb
- Gross weight : 86.1 kg / 189.8 lb
- Box dimension, (L x D x H) : 745 x 275 x 430 mm (29.3" x 10.8" x 16.9")
- *Remark: Only foot forward mounting can meet SAE J706

DIMENSION mm/in :

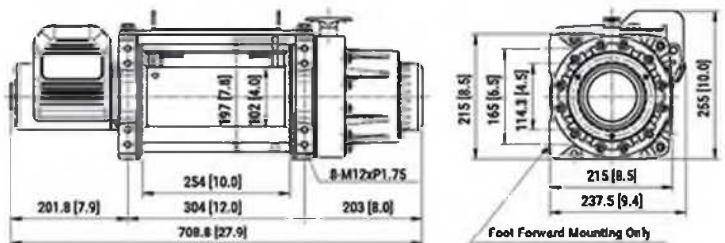

PERFORMANCE DATA :

Line Pull and Rope Capacity

Layer of Rope	Pull by Layer, kg / lb	Total Rope on the Drum, m / ft
1 st	9,980 / 22,000	7.0 / 23
2 nd	8,171 / 18,014	15.5 / 50.9
3 rd	6,917 / 15,249	25 / 82

Line Speed and Amp. Draw (1st layer of rope on the drum)

Line Pull kg / lb	Line Speed, mpm / fpm	Amp. Draw, A 24V
No Load	9.0 / 29.5	30
2,268 / 5,000	3.2 / 10.5	100
4,536 / 10,000	2.5 / 8.2	160
6,804 / 15,000	2.0 / 6.6	240
9,980 / 22,000	1.4 / 4.6	330

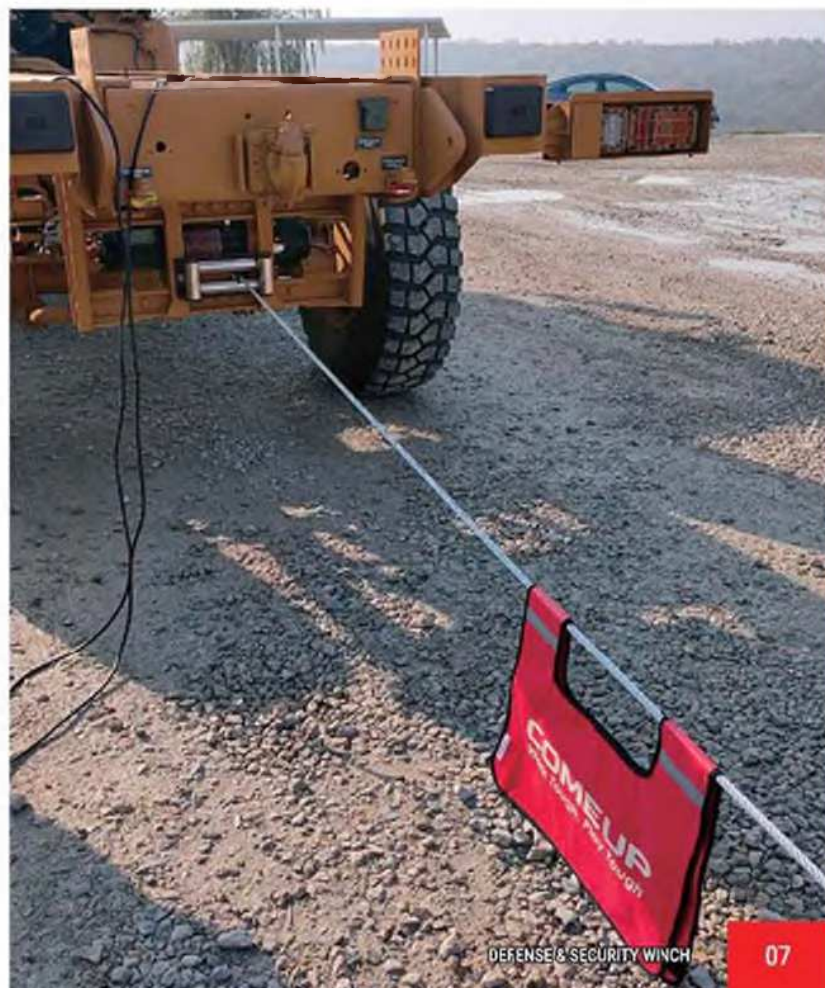



SPECIFICATIONS :

- Rated line pull : 8,165 kg (18,000 lb) single line
- Motor : 5,220 w / 7.0 hp, 12V series wound w/thermal protection switch
4,474 w / 6.0 hp, 24V series wound w/thermal protection switch
- Gear train & ratio : 3-stage planetary 343:1
- Clutch (freespooling) : Rotating ring gear
- Brake (outside the drum) : Automatic, full load CBS (Cone Brake Structure)
- Winch construction : Aluminum die cast housings with steel drum
- Drum size : 89 x 204 mm (3.5" x 8")
- Control : Waterproof remote with thermometric indicator LED w/ 5 m (17') cord
- Rope : 6 x 29 - IWRC (Breaking strength 100.7 kN), 11.1 mm x 27 m (7/16" x 89')
- Recommended battery : 650 CCA minimum for winching
- Battery lead : 1.8 m (6') 2 gauge battery lead
- Mounting bolt pattern : 254 x 114.3 mm (10" x 4.5") ; 254 x 165 mm (10" x 6.5")
- Mounting : Foot forward mounting only
- Winch weight (including rope) : 72 kg / 158.7 lb
- Gross weight : 78 kg / 172 lb
- Box dimension, (L x D x H) : 690 x 270 x 405 mm (27.2" x 10.6" x 15.9")
- *Remark: Only foot forward mounting can meet SAE J706

DIMENSION mm/in :

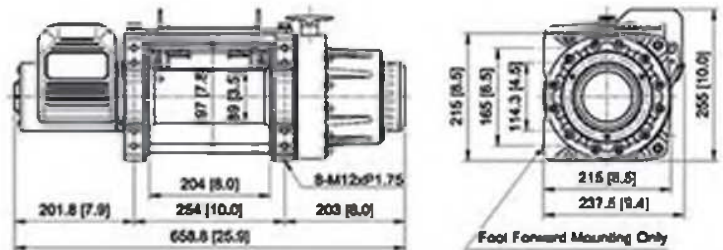

PERFORMANCE DATA :

Line Pull and Rope Capacity

Layer of Rope	Pull by Layer, kg / lb	Total Rope on the Drum, m / ft
1 st	8,165 / 18,000	5.6 / 18.3
2 nd	6,683 / 14,733	12.4 / 40.6
3 rd	5,656 / 12,469	20.4 / 67
4 th	4,903 / 10,809	27 / 89

Line Speed and Amp. Draw (1st layer of rope on the drum)

Line Pull kg / lb	Line Speed, mpm / fpm		Amp. Draw, A	
	12V	24V	12V	24V
No Load	5.2 / 17.1	7.0 / 23	45	35
2,268 / 5,000	2.5 / 8.2	3.5 / 11.5	110	90
4,536 / 10,000	1.6 / 5.2	2.6 / 8.5	190	120
6,804 / 15,000	1.2 / 3.9	2.2 / 7.2	240	170
8,165 / 18,000	0.8 / 2.6	1.7 / 5.6	320	210

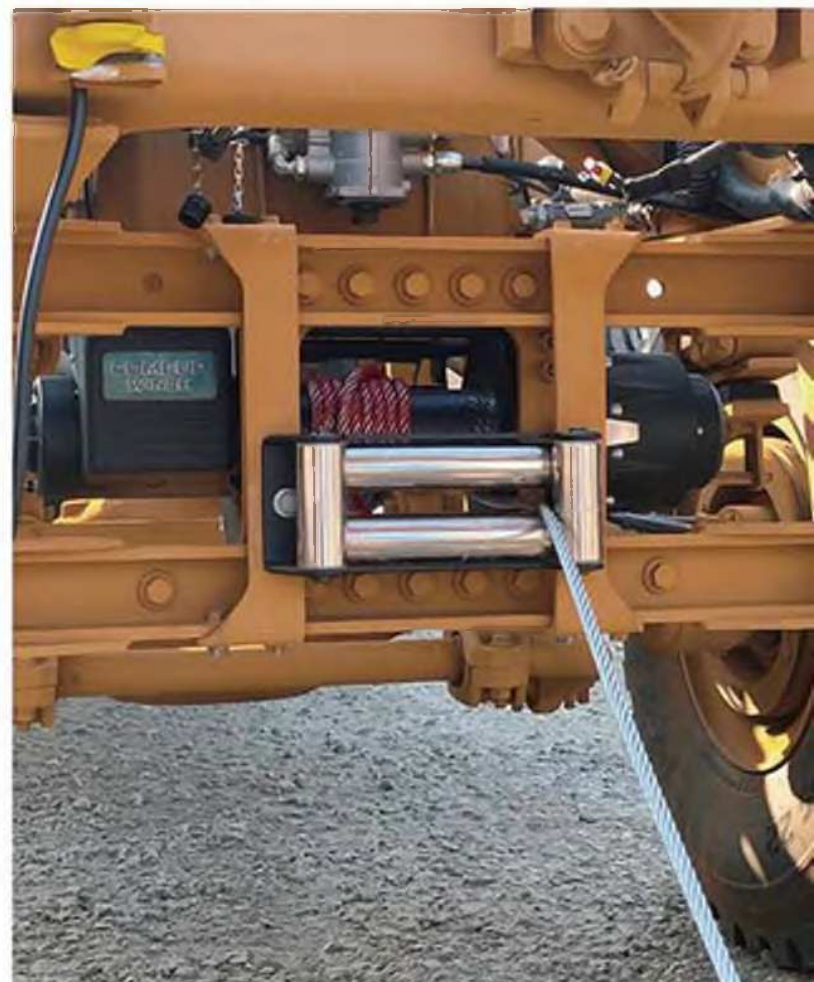

AUTOMOTIVE WINCH

COMEUP winches are equipped with a heavy duty motor that delivering superior torque output and faster line speed for severe duty, self-recovery or utility duty Automotive applications. The Automotive winches come with the U.S., Germany, U.K., France, etc patented automatic CBS (Cone Brace Structure) that completely holds in full load and is easily maintained. Explore and experience the quality of COMEUP automotive winches that are the best solution for 4x4 Trucks and SUVs. They give you power whenever and wherever you need it!

- ▶ Seal Gen2 Series 9,500 20,000 lb
- ▶ Seal Slim Series 9,500 12,500 lb
- ▶ DV Series 4,500 18,000 lb
- ▶ Competition Winch 6,000 10,000 lb
- ▶ Utility Duty Winch 4,500 5,000 lb



COMEUP WINCH

SEAL GEN2 SERIES

9,500 - 12,500 - 16,500 - 20,000 lb pulling capacity

- 1 Submersible Sealed Contactor**
The heavy-duty sealed contactor with silver-alloy contact pads, thick copper buss bars and submersible construction ensures weather resistance. It handles high amps and allows higher duty cycle. The industrial grade contactor is durable, reliable, and high performance.
- 2 Safety Warning Notice**
The built-in waterproof receiver in the control box is equipped with a beeping buzzer to indicate motor overheating. (Only for Seal Gen2 9.5rs/12.5rs/16.5rs/20.0rs)
- 3 Matte Black Powder-coated Finish**
Matte black powder-coated finish on the surfaces allow a deep color expression while also hides the inherent flaws
- 4 Extreme-duty Seals**
Extreme duty, water resistant seals on the motor and gearbox housing joints.
- 5 All Sealed High Performance Motor**
Heavy duty series wound motor delivers superior torque output and faster line speed.
A built-in thermal detector automatically sends a warning signal to the "Remote Control" when motor is over-heated.
- 6 Hardened Steel 3-stage Planetary Gear Train**
Rugged and quiet planetary gears for maximum mechanical efficiency.
- 7 Automatic, Full Load Cone Brake Structure (CBS)**
The U.S. Germany, U.K. France, etc patented brake system automatically holds full load without slipping. With CBS, the greater the load on the rope, the greater amount of braking is generated by the mechanism. Furthermore, the braking mechanism mounted outside the drum rather than inside the drum expedites heat dispersion and also makes this winch ideal for use with synthetic rope.
- 8 Rapid Rope Payout & Clutch Reposition**
An ergonomic T-handle positively engages the free spool clutch through multiple evenly spaced locking holes. The entire clutch can be rotated to reposition the "T" handle in multiple locations, to ease accessibility in various winch mounting positions.
- 9 Protective Thermal Sensor**
The industrial grade waterproof remote control comes with a thermometric LED indicator on the hand-held switch that automatically alerts the operator if the motor begins to overheat, protecting the winch from damage.
- 10 Ergonomic Tie Bar**
Ergonomic matte black powder-coated die cast aluminum alloy tie bar for increased frame strength and better corrosion resistance.
- 11 Rope Options**
Available with either wire rope or lightweight, high strength and no water absorption synthetic rope. Both ropes are equipped with a hook.



Optional Wireless Remote: (See page 40 for more info)

- 1** Wiring harness with built-in antenna designed for quick installation and easy wireless operation.
- 2** IP66 waterproof transmitter and receiver ensure all weather protection.
- 3** 2.4 GHz high frequency device features never in-band interference within 27m (90') radius.
- 4** Color LED indicates different winching conditions.



• Meets international standards of CE Machinery Directive 2006/42/EC, CE Electromagnetic Compatibility Directive 2014/30/EU, and SAE J706 Surface Vehicle standard 2003-08 rev.



Seal Gen2 Series Winch

- ▶ Limited Lifetime Warranty for Mechanical Components.
- ▶ Three (3) Years Warranty for Electrical Components.

Seal Gen2 20.0/20.0s/20.0rs

20,000 LB Electric Winch

Seal Gen2 20.0 **PN 295205** 12V (with wire rope, roller fairlead, remote control)

Seal Gen2 20.0s **PN 295217** 12V (with synthetic rope, hawse fairlead, remote control)

Seal Gen2 20.0rs **PN 295223** 12V (with wireless remote control, synthetic rope, hawse fairlead, remote control)



SPECIFICATIONS :

Rated line pull : 9,072 kg (20,000 lb) single line

Motor : 5,220 w / 7.0 hp, 12V series wound w/thermal protection switch

Gear train & ratio : 3-stage planetary 343:1

Clutch (freespooling) : Rotating ring gear

Brake (outside the drum) : Automatic, full load CBS (Cone Brake Structure)

Winch construction : Aluminum die cast housings with steel drum

Drum size : 89 x 204 mm (3.5" x 8")

Control :

Seal Gen2 20.0/20.0s : Waterproof remote with thermometric indicator LED w/5 m (17') cord

Seal Gen2 20.0rs : Both built-in digital signal two way wireless remote control and waterproof remote with thermometric indicator LED w/5 m (17') cord

Rope : Seal Gen2 20.0 : 6 x 29 - IWRC, 12.7 mm x 18 m (1/2" x 59')

Seal Gen2 20.0s/20.0rs : Synthetic rope, 14 mm x 16.7 m (9/16" x 55')

Recommended battery : 650 CCA minimum for winching

Battery lead : 1.8 m (6') 2 gauge battery lead

Mounting bolt pattern : 254 x 114.3 mm (10" x 4.5"); 254 x 165 mm (10" x 6.5")

Mounting : Foot forward mounting only

Winch weight (including rope) : Seal Gen2 20.0 : 59.9 kg / 132 lb

Seal Gen2 20.0s/20.0rs : 49.6 kg / 109.3 lb

Gross weight : Seal Gen2 20.0 : 77 kg / 169.7 lb

Seal Gen2 20.0s/20.0rs : 63.6 kg / 140.2 lb

Box dimension, (L x D x H) : 740 x 270 x 495 mm (29.1" x 10.6" x 19.5")

*Remark: Only foot forward mounting can meet SAE J706

PERFORMANCE DATA :

Line Pull and Rope Capacity

Model Name	Seal Gen2 20.0		Seal Gen2 20.0s/20.0rs		
	Layer of Rope	Pull by Layer, kg / lb	Total Rope on the Drum, m / ft	Pull by Layer, kg / lb	Total Rope on the Drum, m / ft
1 st		9,072 / 20,000	5.0 / 16.4	9,072 / 20,000	4.6 / 14.9
2 nd		7,259 / 16,003	11.2 / 36.7	7,133 / 15,725	10.3 / 33.9
3 rd		6,050 / 13,338	18.0 / 59.0	5,877 / 12,956	16.7 / 55.0

Line Speed and Amp. Draw (1st layer of rope on the drum)

Line Pull kg / lb	Line Speed, mpm / fpm	Amp. Draw, A
No Load	4.5 / 14.8	60
1,814 / 4,000	2.1 / 6.9	150
3,629 / 8,000	1.8 / 5.9	190
4,536 / 10,000	1.4 / 4.6	260
7,484 / 16,500	1.1 / 3.6	340
9,072 / 20,000	0.4 / 1.3	410

DIMENSION mm/in :

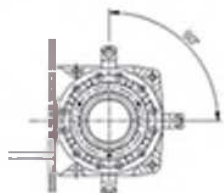
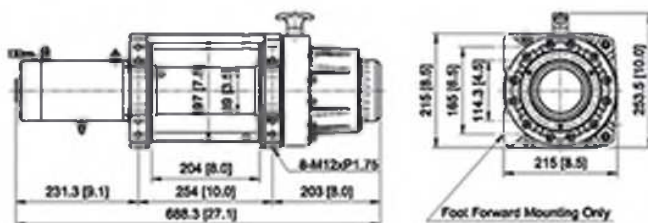

4 equally positioned pin holes ensure seamless clutch transmission and make it easily rotate by 90° increments. (Seal Gen2 20.0/20.0s/20.0rs)



Seal Gen2 16.5/16.5s/16.5rs

16,500 LB Electric Winch

Seal Gen2 16.5 PN 295615 12V (with wire rope, roller fairlead, remote control)

Seal Gen2 16.5s PN 295635 12V (with synthetic rope, hawse fairlead, remote control)

Seal Gen2 16.5rs PN 295655 12V (with wireless remote control, synthetic rope, hawse fairlead, remote control)



Note: Roller/Hawse fairlead does not mount to winch

SPECIFICATIONS :

- Rated line pull : 7,484 kg (16,500 lb) single line
- Motor : 4,325 w / 5.8 hp, 12V series wound w/thermal protection switch
- Gear train & ratio : 3-stage planetary 343:1
- Clutch (freespooling) : Rotating ring gear
- Brake (outside the drum) : Automatic, full load CBS (Cone Brake Structure)
- Winch construction : Aluminum die cast housings with steel drum
- Drum size : 89 x 204 mm (3.5" x 8")
- Control :
- Seal Gen2 16.5/16.5s : Waterproof remote with thermometric indicator LED w/5 m (17') cord
- Seal Gen2 16.5rs : Both built-in digital signal two way wireless remote control and waterproof remote with thermometric indicator LED w/5 m (17') cord
- Rope : Seal Gen2 16.5 : 6 x 29 - IWRC, 11.1 mm x 27.4 m (7/16" x 90')
- Seal Gen2 16.5s/16.5rs : Synthetic rope, 12.7 mm x 25 m (1/2" x 82')
- Recommended battery : 650 CCA minimum for winching
- Battery lead : 1.8 m (6') 2 gauge battery lead
- Mounting bolt pattern : 254 x 114.3 mm (10" x 4.5"); 254 x 165 mm (10" x 6.5')
- Mounting : Foot forward mounting only
- Winch weight (including rope) : Seal Gen2 16.5 : 61 kg / 135 lb
- Seal Gen2 16.5s/16.5rs : 48 kg / 106 lb
- Gross weight : Seal Gen2 16.5 : 76.7 kg / 169 lb
- Seal Gen2 16.5s/16.5rs : 60.8 kg / 134 lb
- Box dimension, (L x D x H) : 690 x 270 x 405 mm (27.2" x 10.6" x 15.9")
- *Remark: Only foot forward mounting can meet SAE J706

PERFORMANCE DATA :

Line Pull and Rope Capacity

Layer of Rope	Pull by Layer, kg / lb	Total Rope on the Drum, m / ft	
		Seal Gen2 16.5	Seal Gen2 16.5s/16.5rs
1 st	7,484 / 16,500	5.6 / 18.4	5.2 / 17.1
2 nd	6,125 / 13,503	12.4 / 40.7	11.6 / 38.1
3 rd	5,184 / 11,429	20.4 / 66.9	19.2 / 63.0
4 th	4,494 / 9,908	27.4 / 90.0	25.0 / 82.0

Line Speed and Amp. Draw (1st layer of rope on the drum)

Line Pull kg / lb	Line Speed, mpm / 1pm		Amp. Draw, A
	Seal Gen2 16.5	Seal Gen2 16.5s/16.5rs	
No Load	5.5 / 18	5.6 / 18.4	50
1,814 / 4,000	2.9 / 9.5	3.0 / 9.8	90
3,629 / 8,000	2.4 / 7.9	2.5 / 8.2	180
4,536 / 10,000	1.8 / 5.9	1.9 / 6.2	230
7,484 / 16,500	1.4 / 4.6	1.4 / 4.6	355

DIMENSION mm/in :

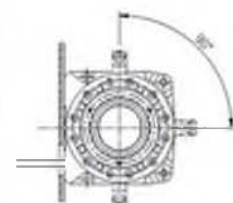
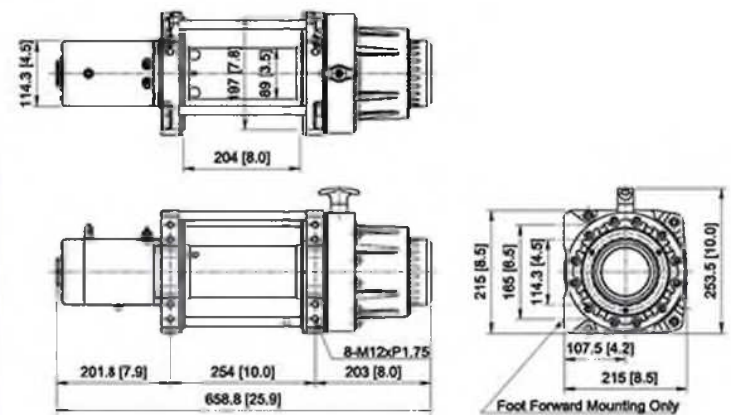

4 equally positioned pin holes ensure seamless clutch transmission and make it easily rotate by 90° increments. (Seal Gen2 16.5/16.5s/16.5rs)



Seal Gen2 12.5/12.5s/12.5rs

12,500 LB Electric Winch

Seal Gen2 12.5 PN 295730 12V (with wire rope, roller fairlead, remote control)

Seal Gen2 12.5s PN 295750 12V (with synthetic rope, hawse fairlead, remote control)

Seal Gen2 12.5rs PN 295780 12V (with wireless remote control, synthetic rope, hawse fairlead, remote control)



Note: Roller/Hawse fairlead does not mount to winch



SPECIFICATIONS :

Rated line pull : 5,670 kg (12,500 lb) single line

Motor : 3,730 w / 5.0 hp, 12V series wound w/thermal protection switch

Gear train & ratio : 3-stage planetary 225:1

Clutch (freespooling) : Rotating ring gear

Brake (outside the drum) : Automatic, full load CBS (Cone Brake Structure)

Winch construction : Aluminum die cast housings with steel drum

Drum size : 63.5 x 227 mm (2.5" x 8.9")

Control :

Seal Gen2 12.5/12.5s : Waterproof remote with thermometric indicator LED w/5 m (17') cord

Seal Gen2 12.5rs : Both built-in digital signal two way wireless remote control and waterproof remote with thermometric indicator LED w/5 m (17') cord

Rope : Seal Gen2 12.5 : Galvanized aircraft A7 x 19, 9.5 mm x 25 m (3/8" x 82')

Seal Gen2 12.5s/12.5rs : Synthetic rope, 11 mm x 25 m (7/16" x 82')

Battery lead : 1.8 m (6') 2 gauge battery lead

Mounting bolt pattern : 254 x 114 mm (10.0" x 4.5")

Mounting : Foot forward mounting only

Winch weight (including rope) : Seal Gen2 12.5 : 37.7 kg / 83.1 lb

Seal Gen2 12.5s/12.5rs : 29.8 kg / 65.7 lb

Gross weight : Seal Gen2 12.5 : 53 kg / 117 lb

Seal Gen2 12.5s/12.5rs : 40.8 kg / 90 lb

Box dimension, (L x D x H) : 682 x 209 x 430 mm (26.9" x 8.2" x 16.9")

Remark : * Only foot forward mounting can meet SAE J706

PERFORMANCE DATA :

Line Pull and Rope Capacity

Layer of Rope	Pull by Layer, kg / lb	Total Rope on the Drum, m / ft	
		Seal Gen2 12.5	Seal Gen2 12.5s/12.5rs
1 st	5,670 / 12,500	5.4 / 17.7	4.8 / 15.7
2 nd	4,499 / 9,919	12.1 / 39.7	10.9 / 35.7
3 rd	3,729 / 8,221	20.3 / 66.6	18.5 / 60.7
4 th	3,184 / 7,020	25.0 / 82.0	25.0 / 82.0

Line Speed and Amp. Draw (1st layer of rope on the drum)

Line Pull kg / lb	Line Speed, mpm / fpm		Amp. Draw, A 12V
	Seal Gen2 12.5	Seal Gen2 12.5s/12.5rs	
No Load	7.5 / 24.6	7.7 / 25.3	45
907 / 2,000	3.4 / 11.2	3.4 / 11.2	75
1,814 / 4,000	2.5 / 8.2	2.5 / 8.2	160
2,722 / 6,000	2.0 / 6.6	2.0 / 6.6	230
3,629 / 8,000	1.6 / 5.2	1.7 / 5.6	300
5,670 / 12,500	0.9 / 3.0	0.9 / 3.0	470

DIMENSION mm/in :

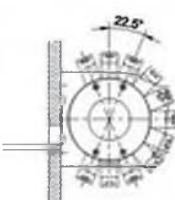
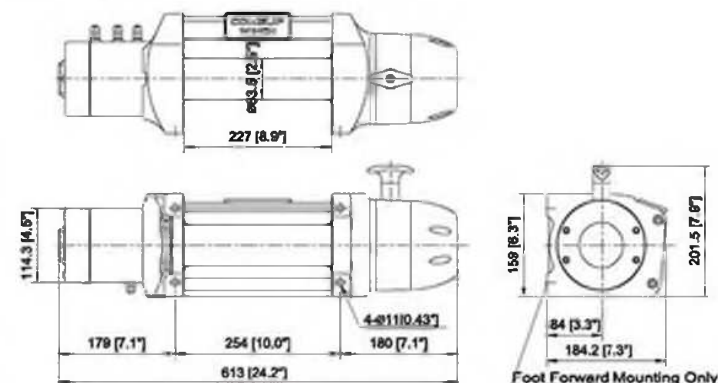

▶ 16 equally positioned pin holes ensure seamless clutch transmission and make it easily rotate by 22.5° increments. (Seal Gen2 12.5/12.5s/12.5rs)

* Please verify specific clutch handle clocking requirements with your dealer prior to purchase.



COMEUP WINCH



Note: Roller/Hawse fairlead does not mount to winch

SPECIFICATIONS :

Rated line pull : 4,309 kg (9,500 lb) single line

Motor : 3,730 w / 5.0 hp, 12V series wound w/thermal protection switch

Gear train & ratio : 3 stage planetary 159:1

Clutch (freespooling) : Rotating ring gear

Brake (outside the drum) : Automatic, full load CBS (Cone Brake Structure)

Winch construction : Aluminum die cast housings with steel drum

Drum size : 63.5 x 227 mm (2.5" x 8.9")

Control :

Seal Gen2 9.5/9.5s : Waterproof remote with thermometric indicator LED w/5 m (17') cord

Seal Gen2 9.5rs : Both built-in digital signal two way wireless remote control and waterproof remote with thermometric Indicator LED w/5 m (17') cord

Rope : Seal Gen2 9.5 : Galvanized aircraft A7 x 19, 8.7 mm x 30.5 m (11/32" x 100')

Seal Gen2 9.5s/9.5rs : Synthetic rope, 10 mm x 30.5 m (3/8" x 100')

Recommended battery : 650 CCA minimum for winchlag

Battery lead : 1.8 m (6') 2 gauge battery lead

Mounting bolt pattern : 254 x 114 mm (10" x 4.5")

Winch weight (including rope) : Seal Gen2 9.5 : 36.2 kg / 79.8 lb

Seal Gen2 9.5s/9.5rs : 28.5 kg / 62.8 lb

Gross weight : Seal Gen2 9.5 : 51.3 kg / 113 lb

Seal Gen2 9.5s/9.5rs : 40 kg / 88 lb

Box dimension, (L x D x H) : 682 x 209 x 430 mm (26.9" x 8.2" x 16.9")

Seal Gen2 9.5/9.5s/9.5rs

9,500 LB Electric Winch

Seal Gen2 9.5 PN 295950 12V (with wire rope, roller fairlead, remote control)

Seal Gen2 9.5s PN 295990 12V (with synthetic rope, hawse fairlead, remote control)

Seal Gen2 9.5rs PN 295850 12V (with wireless remote control, synthetic rope, hawse fairlead, remote control)



PERFORMANCE DATA :

Line Pull and Rope Capacity

Layer of Rope	Pull by Layer, kg / lb	Total Rope on the Drum, m / ft	
		Seal Gen2 9.5	Seal Gen2 9.5s/9.5rs
1 st	4,309 / 9,500	5.8 / 19.1	5.1 / 16.7
2 nd	3,472 / 7,655	13.1 / 42.9	11.7 / 38.4
3 rd	2,908 / 6,410	21.7 / 71.2	19.7 / 64.6
4 th	2,501 / 5,514	30.5 / 100	30.5 / 100

Line Speed and Amp. Draw (1st layer of rope on the drum)

Line Pull kg / lb	Line Speed, mpm / fpm		Amp. Draw, A 12V
	Seal Gen2 9.5	Seal Gen2 9.5s/9.5rs	
No Load	14.5 / 47.6	14.8 / 48.6	60
907 / 2,000	4.7 / 15.2	4.8 / 15.7	115
1,814 / 4,000	3.5 / 11.5	3.6 / 11.8	210
2,722 / 6,000	2.8 / 9.2	2.8 / 9.2	245
3,629 / 8,000	2.3 / 7.6	2.3 / 7.6	280
4,309 / 9,500	2.1 / 6.8	2.2 / 7.2	380

DIMENSION mm/in :

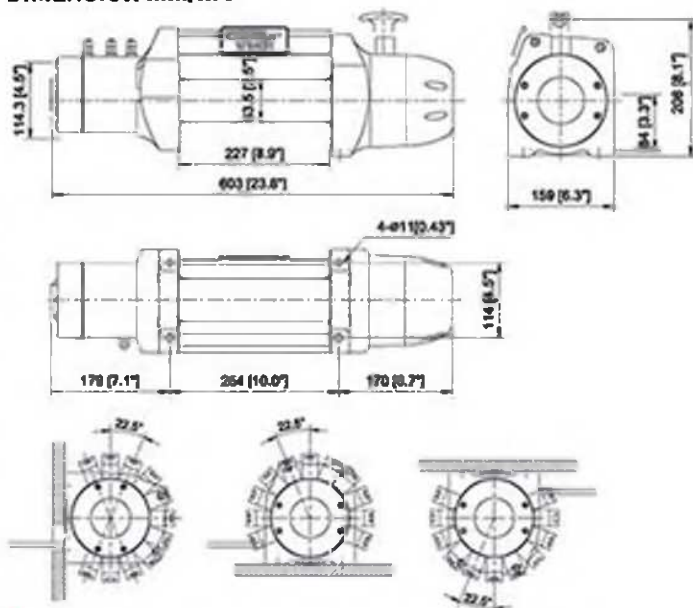

16 equally positioned pin holes ensure seamless clutch transmission and make it easily rotate by 22.5° increments. Seal Gen2 9.5/9.5s/9.5rs

• Please verify specific clutch handle coloring requirements with your dealer prior to purchase.





**TAIWAN
EXCELLENCE
2017**

New functions of the bridge control box

Intelligence Dashboard (IDB) - Included On Seal Gen2 9.5i /9.5si/9.5rsi Models



Vehicle Battery Life

The Intelligence Dashboard (IDB) displays the condition of your vehicle's battery.



Wireless Remote Control Icon - Seal Gen2 9.5rsi Only

Wireless Signal Icon

The Intelligence Dashboard (IDB) includes a blue wireless signal icon that is continuously illuminated to confirm the wireless remote is paired with the winch.



Wireless Signal Strength

The solid green LED on the wireless transmitter indicates good signal strength, but a flashing red LED indicates a weak signal.



Cable IN/OUT Direction Indicators

The green triangle icons on the Intelligence Dashboard (IDB) will light sequentially to indicate the rope winding direction. The green triangles will turn to red triangles if the motor is over-heating.

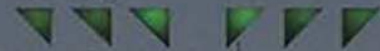

Thermal Protection

Temperature Warning

The flashing red temperature icon on the Intelligence Dashboard (IDB) indicates the motor is over-heating.



Handheld Remote Warning

The two green LEDs on the wired remote control will change to red if the motor is over-heating.



Buzzer Warning

The Seal Gen2 9.5rs/9.5rsi/12.5rs/16.5rs/20.0rs models include an audible buzzer alarm that alerts if the motor is over-heating.



Cutout Switch

- The Seal Gen2 9.5i/9.5si models include a cutout switch to activate or deactivate the winch.
- The cutout switch on the Seal Gen2 9.5rsi model also deactivate the wireless receiver to prevent parasitic draw.



COMEUP WINCH

Seal Gen2 9.5i/9.5si/9.5rsi 9,500 LB Electric Winch

Seal Gen2 9.5i PN 295980 12V (with wire rope, roller fairlead, remote control)

Seal Gen2 9.5si PN 295880 12V (with synthetic rope, hawse fairlead, remote control)

Seal Gen2 9.5rsi PN 295860 12V (with wireless remote control, synthetic rope, hawse fairlead, remote control)



Note : Roller/Hawse fairlead does not mount to winch



SPECIFICATIONS :

- Rated line pull : 4,309 kg (9,500 lb) single line
- Motor : 3,730 w / 5.0 hp, 12V series wound w/thermal protection switch
- Gear train & ratio : 3-stage planetary 159:1
- Clutch (freespooling) : Rotating ring gear
- Brake (outside the drum) : Automatic, full load CBS (Cone Brake Structure)
- Winch construction : Aluminum die cast housings with steel drum
- Drum size : 63.5 x 227 mm (2.5" x 8.9")
- Control :
 - Seal Gen2 9.5i/9.5si : Waterproof remote with thermometric indicator LED w/5 m (17') cord
 - Seal Gen2 9.5rsi : Both built-in digital signal two way wireless remote control and waterproof remote with thermometric indicator LED w/5 m (17') cord
- Rope : Seal Gen2 9.5i : Galvanized aircraft A7 x 19, 8.7 mm x 30.5 m (11/32" x 100')
Seal Gen2 9.5si/9.5rsi : Synthetic rope, 10 mm x 30.5 m (3/8" x 100')
- Recommended battery : 650 CCA minimum for winching
- Battery lead : 1.8 m (6') 2 gauge battery lead
- Mounting bolt pattern : 254 x 114 mm (10" x 4.5")
- Winch weight (including rope) : Seal Gen2 9.5i : 38.5 kg / 85 lb
Seal Gen2 9.5si/9.5rsi : 36.2 kg / 79.8 lb
- Gross weight : Seal Gen2 9.5i : 52.6 kg / 116 lb
Seal Gen2 9.5si/9.5rsi : 40.8 kg / 90 lb
- Box dimension, (L x D x H) : 682 x 209 x 430 mm (26.9" x 8.2" x 16.9")

PERFORMANCE DATA :

Line Pull and Rope Capacity

Layer of Rope	Pull by Layer, kg / lb	Total Rope on the Drum, m / ft	
		Seal Gen2 9.5i	Seal Gen2 9.5si/9.5rsi
1 st	4,309 / 9,500	5.8 / 19.1	5.1 / 16.7
2 nd	3,472 / 7,655	13.1 / 42.9	11.7 / 38.4
3 rd	2,908 / 6,410	21.7 / 71.2	19.7 / 64.6
4 th	2,501 / 5,514	30.5 / 100	30.5 / 100

Line Speed and Amp. Draw (1st layer of rope on the drum)

Line Pull kg / lb	Line Speed, mpm / fpm		Amp. Draw, A 12V
	Seal Gen2 9.5i	Seal Gen2 9.5si/9.5rsi	
No Load	14.5 / 47.6	14.8 / 48.6	60
907 / 2,000	4.7 / 15.2	4.8 / 15.7	115
1,814 / 4,000	3.5 / 11.5	3.6 / 11.8	210
2,722 / 6,000	2.8 / 9.2	2.8 / 9.2	245
3,629 / 8,000	2.3 / 7.6	2.3 / 7.6	280
4,309 / 9,500	2.1 / 6.8	2.2 / 7.2	380

DIMENSION mm/in :

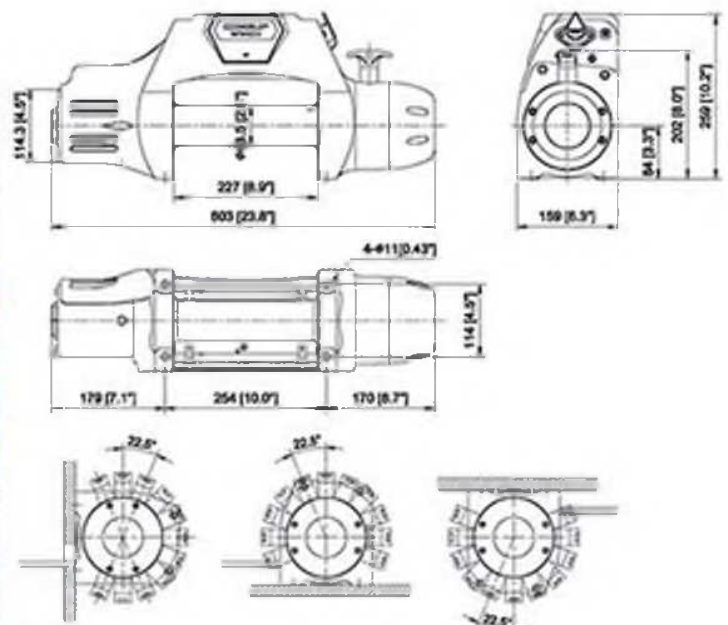

16 equally positioned pin holes ensure seamless clutch transmission and make it easily rotate by 22.5° increments. (Seal Gen2 9.5i/9.5si/9.5rsi)



**COMEUP
WINCH**

Seal Slim Series

9,500 - 12,500 lb pulling capacity

- 12V DC severe duty winch
- Slim size for hidden, inside-bumper mounting applications
- Die-Cast housing tested to twice the rated winch capacity
- Patented CBS (Cone Brake Structure) for safe, full-load holding
- Built-In digital two way wireless remote control
- Heavy-duty series wound motor delivers superior torque output
- Thermal overload warning and motor protection
- Clockable clutch lever for easy operation in concealed applications
- Hardened steel, planetary gear train for durable and reliable operation
- Coated 12 strand synthetic rope with superior abrasion resistance
- Includes waterproof wired remote control and hawse fairlead



- Seal Slim Series Winch
- ▶ Limited Lifetime Warranty for Mechanical Components
 - ▶ Three (3) years Warranty for Electrical Components

COMEUP WINCH

Seal Slim 12.5rs

12,500 LB Electric Winch

PN 295059 12V (with wireless remote control, synthetic rope, hawse fairlead, remote control)



Note : Hawse fairlead does not mount to winch

SPECIFICATIONS :

- Rated line pull : 5,670 kg (12,500 lb) single line
- Motor : 3,730 w / 5.0 hp 12V, series wound w/thermal protection switch
- Gear train & ratio : 3-stage planetary 225:1
- Clutch (treespooling) : Rotating ring gear
- Brake (outside the drum) : Automatic, full load CBS (Cone Brake Structure)
- Winch construction : Aluminum die cast housings with steel drum
- Drum size : 63.5 x 227 mm (2.5" x 8.9")
- Control : Both built-in digital signal two way wireless remote control and waterproof remote with thermometric indicator LED w/5 m (17') cord
- Rope : Synthetic rope, 11 mm x 25 m (7/16" x 82')
- Battery lead : 1.8 m (6') 2 gauge battery lead
- Mounting bolt pattern : 254 x 114 mm (10" x 4.5")
- Mounting : Foot forward mounting only
- Winch weight (including rope) : 29.8 kg / 65.7 lb
- Gross weight : 40.8 kg / 90 lb
- Box dimension, (L x D x H) : 682 x 209 x 430 mm (26.9" x 8.2" x 16.9")
- Remark : * Only foot forward mounting can meet SAE J706

PERFORMANCE DATA :

Line Pull and Rope Capacity

Layer of Rope	Pull by Layer, kg / lb	Total Rope on the Drum, m / ft
1 st	5,670 / 12,500	4.8 / 15.7
2 nd	4,499 / 9,919	10.9 / 35.7
3 rd	3,729 / 8,221	18.5 / 60.7
4 th	3,184 / 7,020	25.0 / 82.0

Line Speed and Amp. Draw (1st layer of rope on the drum)

Line Pull kg / lb	Line Speed, mpm / fpm	Amp. Draw, A 12V
No Load	7.7 / 25.3	45
907 / 2,000	3.4 / 11.2	75
1,814 / 4,000	2.5 / 8.2	160
2,722 / 6,000	2.0 / 6.6	230
3,629 / 8,000	1.7 / 5.6	300
5,670 / 12,500	0.9 / 3.0	470

DIMENSION mm/in :

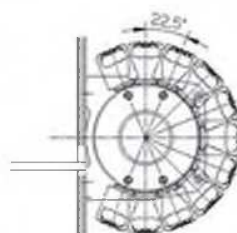
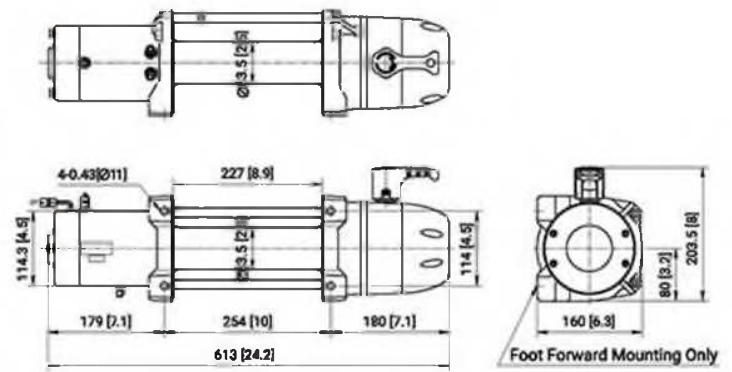

▶ 16 equally positioned pin holes ensure seamless clutch transmission and make it easily rotate by 22.5° increments.

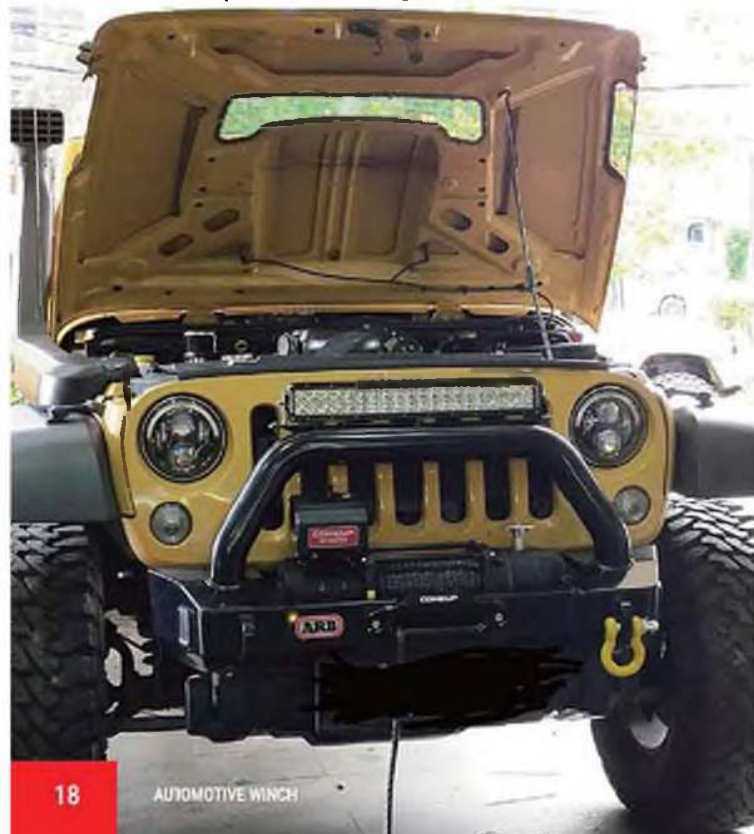

Seal Slim 9.5rs

9,500 LB Electric Winch

PN 295053 12V (with wireless remote control, synthetic rope, hawse fairlead, remote control)



Note: Hawse fairlead does not mount to winch

SPECIFICATIONS :

Rated line pull : 4,309 kg (9,500 lb) single line

Motor : 3,730 w / 5.0 hp, 12V series wound w/thermal protection switch

Gear train & ratio : 3-stage planetary 159:1

Clutch (freespooling) : Rotating ring gear

Brake (outside the drum) : Automatic, full load CBS (Cone Brake Structure)

Winch construction : Aluminum die cast housings with steel drum

Drum size : 63.5 x 227 mm (2.5" x 8.9")

Control : Both built-in digital signal two way wireless remote control and waterproof remote with thermometric indicator LED w/5 m (17') cord

Rope : Synthetic rope, 10 mm x 30.5 m (3/8" x 100')

Recommended battery : 650 CCA minimum for winching

Battery lead : 1.8 m (6') 2 gauge battery lead

Mounting bolt pattern : 254 x 114 mm (10" x 4.5")

Winch weight (including rope) : 28.5 kg / 62.8 lb

Gross weight : 40 kg / 88 lb

Box dimension, (L x D x H) : 682 x 209 x 430 mm (26.9" x 8.2" x 16.9")

PERFORMANCE DATA :

Line Pull and Rope Capacity

Layer of Rope	Pull by Layer, kg / lb	Total Rope on the Drum, m / ft
1 st	4,309 / 9,500	55.1 / 16.7
2 nd	3,472 / 7,655	11.7 / 38.4
3 rd	2,908 / 6,410	19.7 / 64.6
4 th	2,501 / 5,514	30.5 / 100

Line Speed and Amp. Draw (1st layer of rope on the drum)

Line Pull kg / lb	Line Speed, mpm / fpm	Amp. Draw, A 12V
No Load	14.8 / 48.6	60
907 / 2,000	4.8 / 15.7	115
1,814 / 4,000	3.6 / 11.8	210
2,722 / 6,000	2.8 / 9.2	245
3,629 / 8,000	2.3 / 7.6	280
4,309 / 9,500	2.2 / 7.2	380

DIMENSION mm/in :

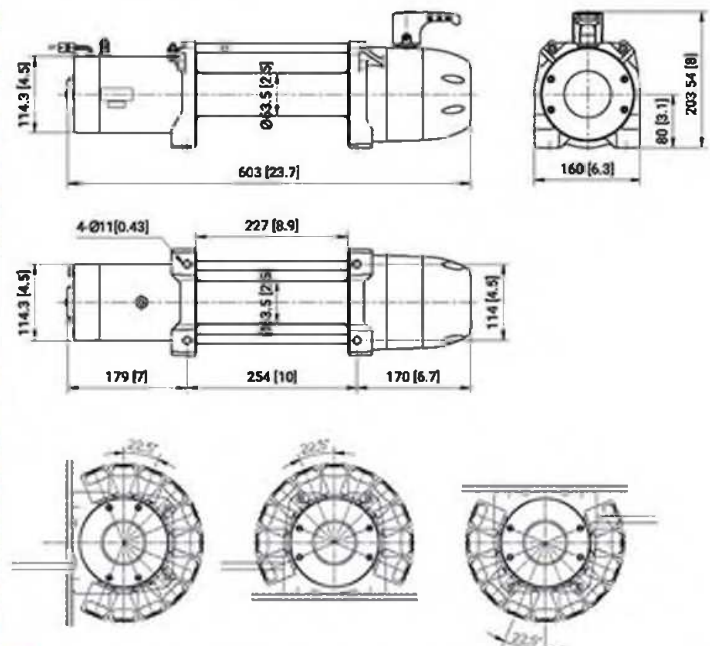

16 equally positioned pin holes ensure seamless clutch transmission and make it easily rotate by 22.5° increments.

AUTOMOTIVE WINCH



DV Series

6,000 - 9,000 - 12,000 - 15,000 - 18,000 lb pulling capacity

** All DV series winches with synthetic rope upon request. **

- Submersible Sealed Contactor**
The heavy-duty sealed contactor with silver alloy contact pads, thick copper buss bars and a bumperless construction ensures weather resistance. It handles high amps and a lower higher duty cycle. The industrial grade contactor is durable, reliable, and high performance.
- Extreme Durable Motor**
Heavy duty series wound motor delivers superior torque output and faster line speed.
- Aluminum Alloy Housings**
Tough die cast aluminum alloy housings can withstand forces greater than 2 times the winch's rated capacity.
- Hardened Steel 3-stage Planetary Gear Train**
Rugged and quiet planetary gears for maximum mechanical.
- Rapid Rope Payout & Clutch Reposition**
An ergonomic Handle positively engages the free spool clutch through multiple evenly spaced locking holes. The entire clutch can be rotated to reposition the "T" handle in multiple locations to ease accessibility in various winch mounting positions.
- Automatic, Full Load Cone Brake Structure (CBS)**
The U.S. Germany, U.K. France, etc patented brake system automatically holds full load without slipping. With CBS, the greater the load on the rope, the greater amount of braking is generated by the mechanism. Furthermore, the braking mechanism mounted outside the drum rather than inside the drum expedites heat dispersion and also makes this winch ideal for use with synthetic rope.



7 Protective Thermal Sensor LED
The industrial grade waterproof remote control comes with a thermometric LED indicator on the hand-held switch that automatically alerts the operator if the motor begins to overheat, protecting the winch from damage.

• Meets international standards of CE, Machinery Directive 2006/42/CE, CE Electromagnetic Compatibility Directive 2014/53/EU, and SAE J706 Surface Vehicle standard 2002-08 rev.

▶ **Limited Lifetime Warranty for Mechanical Components**
▶ **One (1) Year Warranty for Electrical Components**



DV-18

18,000 LB Electric Winch

PN 851823 12V / PN 851838 24V
(with wire rope, roller fairlead, remote control)



Note: Roller fairlead does not mount to winch

SPECIFICATIONS :

Rated line pull: 8,181 kg (18,000 lb) single line

Motor : 5,220 w / 7.0 hp, 12V series wound w/thermal protection switch
4,974 w / 6.0 hp, 24V series wound w/thermal protection switch

Gear train & ratio : 3-stage planetary 31.5:1

Clutch (free-spooling) : Rotating ring gear

Brake (outside the drum) : Automatic, full load CBS (Cone Brake Structure)

Winch construction : Aluminum die cast housings with steel drum

Drum size : 89 x 192 mm (3.5" x 7.6")

Control : Waterproof remote with thermometric indicator LED w/5 m (17') cord

Rope : 6 x 29 - IWRB, 12.7 mm x 25 m (1/2" x 82')

Recommended battery : 650 CCA minimum for winching

Battery lead : 1.8 m (6') 2 gauge battery lead

Mounting bolt pattern : 254 x 114 mm (10" x 4.5") ; 254 x 165 mm (10" x 6.5")

Mounting : Foot forward mounting only

Winch weight (including rope) : 59 kg / 130 lb

Gross weight : 71 kg / 156.5 lb

Box dimension, (L x D x H) : 694.2 x 365.2 x 418.4 mm (27.3" x 10.4" x 16.5")

PERFORMANCE DATA :

Line Pull and Rope Capacity

Layer of Rope	Pull by Layer, kg / lb	Total Rope on the Drum, m / ft
1 st	8,181 / 18,000	4.7 / 15.4
2 nd	6,546 / 14,431	10.5 / 34.4
3 rd	5,456 / 12,028	17.5 / 57.4
4 th	4,677 / 10,311	25.0 / 82.0

Line Speed and Amp. Draw (1st layer of rope on the drum)

Line Pull kg / lb	Line Speed mpm / fpm	Amp. Draw, A 12V / 24V
No Load	8.6 / 28.2	35 / 40
1,814 / 4,000	4.0 / 13.1	115 / 70
3,630 / 8,000	3.6 / 12.0	200 / 140
4,535 / 10,000	3.2 / 10.6	230 / 180
5,443 / 12,000	2.8 / 9.3	260 / 210
6,604 / 15,000	2.3 / 7.5	320 / 240
8,181 / 18,000	1.0 / 3.3	350 / 290

DIMENSION mm/in :

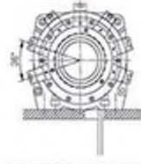
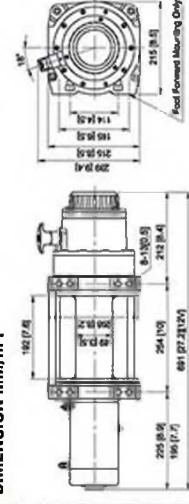

10 equally positioned pin holes ensure seamless clutch transmission and make it easily rotate by 36° increments.



15,000/12,000 LB Electric Winch

DV-15 PN 857326 12V | PN 857431 24V (with wire rope, roller fairlead, remote control)
 DV-12 PN 857130 12V | PN 857228 24V (with wire rope, roller fairlead, remote control)



Note : Roller fairlead does not mount to winch

SPECIFICATIONS :

- Rated line pull :
 - DV-15 : 6,804 kg (15,000 lb) single line
 - DV-12 : 5,443 kg (12,000 lb) single line
- Motor : 4,180 w / 5.6 hp, 12V series wound w/thermal protection switch
 2,690 w / 3.6 hp, 24V series wound w/thermal protection switch
- Gear train & ratio : DV-15 : 3-stage planetary 315:1
 DV-12 : 3-stage planetary 261:1
- Clutch (freespooling) : Rotating ring gear
- Brake (outside the drum) : Automatic, full load CBS (Cone Brake Structure)
- Winch construction : Aluminum die cast housings with steel drum
- Drum size : 89 mm x 206 mm (3.5" x 8.1")
- Control : Waterproof remote with thermometric indicator LED w/5 m (17') cord
- Rope : DV-15 : 6 x 29 - IWRC, 11.1 mm x 27 m (7/16" x 89)
 DV-12 : Galvanized aircraft A7 x 19, 9.5 mm x 39 m (3/8" x 125)
- Recommended battery : 650 CCA minimum for winching
- Battery lead : 1.8 m (6') 2 gauge battery lead
- Mounting bolt pattern : 254 x 114 mm (10" x 4.5"); 254 x 165 mm (10" x 6.5")
- Winch weight (including rope) : DV-15 : 57 kg / 125.4 lb ; DV-12 : 55 kg / 121 lb
- Gross weight : DV-15 : 69 kg / 152 lb ; DV-12 : 67 kg / 147.7 lb
- Box dimension, (L x D x H) : 694 x 265.2 x 418.4 mm (27.3" x 10.4" x 16.5")

PERFORMANCE DATA :

Line Pull and Rope Capacity

Layer of Rope	DV-15		DV-12	
	Pull by Layer, kg / lb	Total Rope on the Drum, m / ft	Pull by Layer, kg / lb	Total Rope on the Drum, m / ft
1 st	6,804 / 15,000	5.7 / 18.6	5,443 / 12,000	6.6 / 21.5
2 nd	5,569 / 12,277	12.6 / 41.4	4,563 / 10,060	14.4 / 47.2
3 rd	4,713 / 10,391	20.8 / 68.3	3,928 / 8,659	23.5 / 77
4 th	4,086 / 9,007	27 / 89	3,448 / 7,601	33.8 / 110.9
5 th	-	-	3,072 / 6,774	38 / 125

Line Speed and Amp. Draw (1st layer of wire rope on the drum)

Line Pull kg / lb	Line Speed, mpm / fpm		Amp. Draw, A			
	DV-15	DV-12	DV-15		DV-12	
			12V	24V	12V	24V
No Load	6.9 / 22.0	8.3 / 27	60	50	60	50
1,814 / 4,000	1.6 / 5.4	2.6 / 8.6	180	80	200	100
3,629 / 8,000	1.2 / 3.8	1.7 / 5.8	280	190	310	190
4,536 / 10,000	1.0 / 3.3	1.4 / 4.4	330	220	370	230
5,443 / 12,000	0.9 / 2.9	1.2 / 4.0	385	260	440	290
6,804 / 15,000	0.8 / 2.5	-	460	340	-	-

DIMENSION mm/in : (DV-15/12)

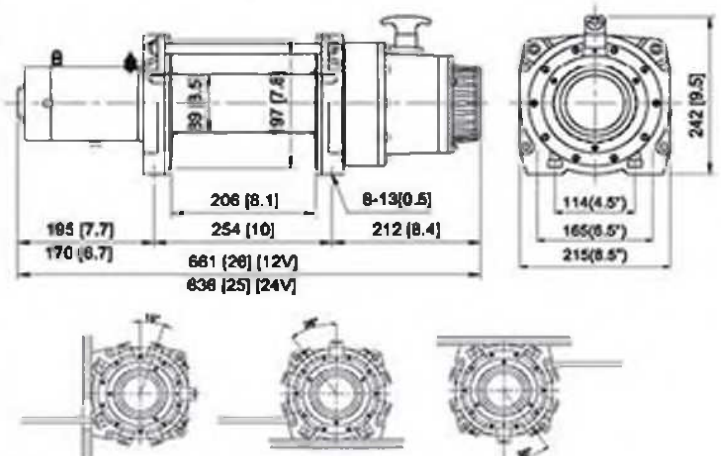

10 equally positioned pin holes ensure seamless clutch transmission and make it easily rotate by 36° increments. (DV-15/12)



DV-12 light/12s light

12,000 LB Electric Winch

DV-12 light PN 850012 12V | PN 850124 24V (with wire rope, roller fairlead, remote control)

DV-12s light PN 850125 12V | PN 851024 24V (with synthetic rope, hawse fairlead, remote control)



Note : Roller/Hawse fairlead does not mount to winch

SPECIFICATIONS :

- Rated line pull : 5,443 kg (12,000 lb) single line
- Motor : 3,430 w / 4.6 hp, 12V series wound w/thermal protection switch
1,940 w / 2.6 hp, 24V series wound w/thermal protection switch
- Gear train & ratio : 3-stage planetary 211:1
- Clutch (freespooling) : Rotating ring gear
- Brake (outside the drum) : Automatic, full load CBS (Cone Brake Structure)
- Winch construction : Aluminum die cast housings with steel drum
- Drum size : 63.5 x 227 mm (2.5" x 8.9")
- Control : Waterproof remote with thermometric indicator LED w/5 m (17') cord
- Rope : DV-12 light : Galvanized aircraft A7 x 19, 9.5 mm x 25 m (3/8" x 82')
DV-12s light : Synthetic rope, 11 mm x 25 m (7/16" x 82')
- Recommended battery : 650 CCA minimum for winching
- Battery lead : 1.8 m (6') 2 gauge battery lead
- Mounting bolt pattern : 254 x 114 mm (10" x 4.5")
- Mounting : Foot forward mounting only
- Winch weight (including rope) : DV-12 light : 39 kg / 86 lb
DV-12s light : 30 kg / 66.1 lb
- Gross weight : DV-12 light : 49 kg / 108 lb
DV-12s light : 36 kg / 79.4 lb
- Box dimension, (L x D x H) : 650 x 195 x 415 mm (25.6" x 7.7" x 16.3")
- Remark : * Only foot forward mounting can meet SAE J706

PERFORMANCE DATA :

Line Pull and Rope Capacity

Layer of Rope	Pull by Layer, kg / lb	Total Rope on the Drum, m / ft	
		DV-12 light	DV-12s light
1 st	5,443 / 12,000	5.4 / 17.7	4.7 / 15.5
2 nd	4,319 / 9,521	12.2 / 40.0	10.8 / 35.5
3 rd	3,580 / 7,893	20.5 / 67.3	18.3 / 60.1
4 th	3,056 / 6,731	25.0 / 82.0	25.0 / 82.0

Line Speed and Amp. Draw (1st layer of rope on the drum)

Line Pull kg / lb	Line Speed, mpm / fpm		Amp. Draw, A	
	DV-12 light	DV-12s light	12V	24V
No Load	8.0 / 26.2	8.2 / 26.9	50	30
1,814 / 4,000	3.0 / 9.8	3.1 / 10.2	120	70
3,629 / 8,000	1.5 / 5.0	1.6 / 5.1	230	140
4,536 / 10,000	1.2 / 4.0	1.2 / 4.0	290	180
5,443 / 12,000	1.0 / 3.3	1.0 / 3.3	350	210

DIMENSION mm/in :

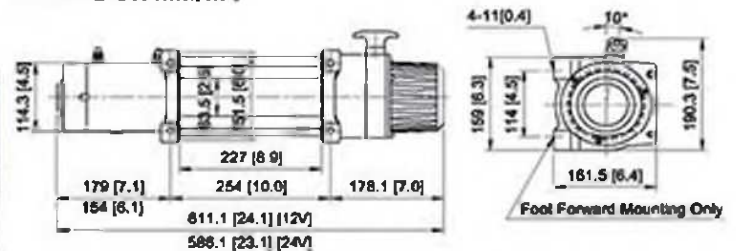

Foot Forward Mounting Only

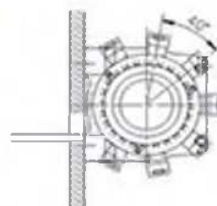

9 equally positioned pin holes ensure seamless clutch transmission and make it easily rotate by 40° increments. (DV-12 light/12s light)



COMEUP WINCH

DV-9/9s

9,000 LB Electric Winch

DV-9 PN 856329 12V | PN 856355 24V (with wire rope, roller fairlead, remote control)
 DV-9s PN 859252 12V | PN 859262 24V (with synthetic rope, hawse fairlead, remote control)



Note: Roller/Hawse fairlead does not mount to winch

DIMENSION mm/in :

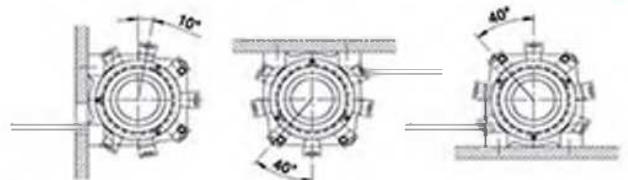
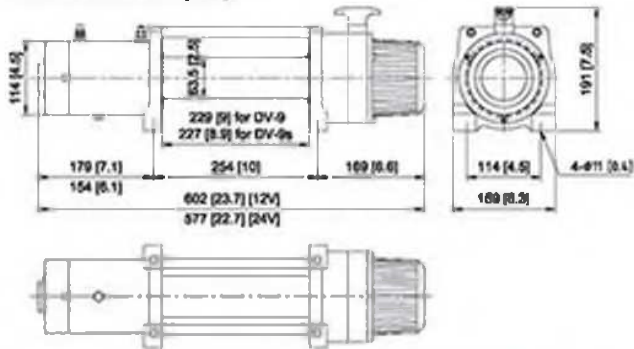

9 equally positioned pin holes ensure seamless clutch transmission and make it easy to rotate by 40° increments. (DV-9i/9si/9/9s)



DV-9i/9si

9,000 LB Electric Winch

DV-9i PN 856360 12V | PN 856388 24V (with wire rope, roller fairlead, remote control)

DV-9si PN 859038 12V | PN 859055 24V (with synthetic rope, hawse fairlead, remote control)



SPECIFICATIONS :

- Rated line pull : 4,082 kg (9,000 lb) single line
- Motor : 3,430 w / 4.6 hp, 12V series wound w/thermal protection switch
1,940 w / 2.6 hp, 24V series wound w/thermal protection switch
- Gear train & ratio : 3-stage planetary 156:1
- Clutch (freespooling) : Rotating ring gear
- Brake (outside the drum) : Automatic, full load CBS (Cone Brake Structure)
- Winch construction : Aluminum die cast housings with steel drum
- Drum size : DV-9/9i : 63.5 x 229 mm (2.5" x 9")
DV-9s/9si : 63.5 x 227 mm (2.5" x 8.9")
- Control : Waterproof remote with thermometric indicator LED w/5 m (17') cord
- Rope : DV-9/9i : Galvanized aircraft A7 x 19, 8.3 mm x 30.5 m (21/64" x 100')
DV-9s/9si : Synthetic rope, 10 mm x 30.5 m (3/8" x 100')
- Recommended battery : 650 CCA minimum for winching
- Battery lead : 1.8 m (6') 2 gauge battery lead
- Mounting bolt pattern : 254 x 114 mm (10" x 4.5")
- Winch weight (including rope) : DV-9 : 33 kg / 72.8 lb ; DV-9s : 27 kg / 59.5 lb
DV-9i : 37 kg / 81.6 lb ; DV-9si : 31 kg / 68.3 lb
- Gross weight : DV-9 : 43 kg / 94.8 lb ; DV-9s : 33 kg / 72.8 lb
DV-9i : 44 kg / 97 lb ; DV-9si : 37 kg / 81.6 lb
- Box dimension, (L x D x H) : 650 x 195 x 415 mm (25.6" x 7.7" x 16.3")

PERFORMANCE DATA :

Line Pull and Rope Capacity

Layer of Rope	Pull by Layer, kg / lb	Total Rope on the Drum, m / ft	
		DV-9/9i	DV-9s/9si
1 st	4,082 / 9,000	6.1 / 20.0	5.5 / 18.1
2 nd	3,316 / 7,310	13.6 / 44.7	12.5 / 41.0
3 rd	2,792 / 6,154	22.6 / 74.0	20.9 / 68.6
4 th	2,410 / 5,314	30.5 / 100	30.5 / 100

Line Speed and Amp. Draw (1st layer of rope on the drum)

Line Pull kg / lb	Line Speed, mpm / fpm		Amp. Draw, A	
	DV-9/9i	DV-9s/9si	12V	24V
No Load	13 / 42.7	13.2 / 43.3	55	30
907 / 2,000	4.6 / 15.0	4.7 / 15.3	110	65
1,814 / 4,000	3.4 / 11.0	3.4 / 11.2	200	100
2,722 / 6,000	2.7 / 9.0	2.8 / 9.1	230	130
3,629 / 8,000	2.3 / 7.5	2.3 / 7.6	260	170
4,082 / 9,000	2.0 / 6.4	2.0 / 6.5	350	210

DIMENSION mm/in :

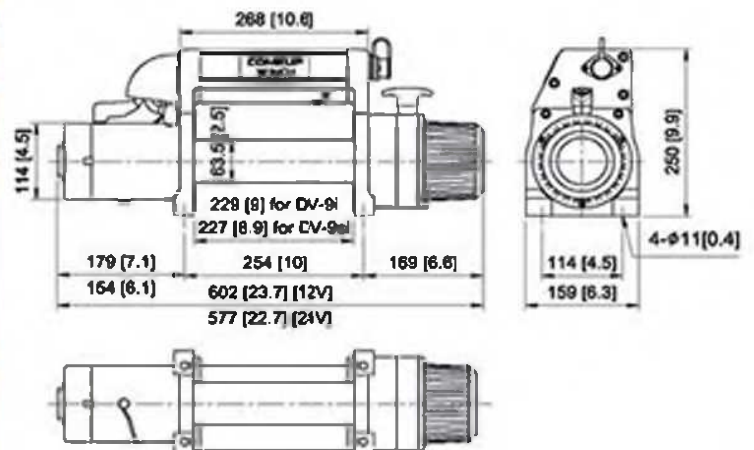

6,000 LB Electric Winch

PN 854750 12V Std. drum | PN 854760 12V Long drum
(with wire rope, roller fairlead, remote control)



SPECIFICATIONS :

- Rated line pull : 2,722 kg (6,000 lb) single line
- Motor : 2,390 w / 3.2 hp, 12V series wound
- Gear train & ratio : 3-stage planetary 216:1
- Clutch (freespooling) : Rotating ring gear
- Brake (outside the drum) : Automatic, full load CBS (Cone Brake Structure)
- Winch construction : Aluminum die cast housings and strong steel drum
- Drum size : Std. drum : 63.5 x 125.5 mm (2.5" x 4.9")
Long drum : 63.5 x 227 mm (2.5" x 8.9")
- Control : Waterproof remote w/5 m (17') cord
- Rope : Std. drum : Galvanized aircraft A7 x 19, 7.1 mm x 24.4 m (9/32" x 80")
Long drum : Galvanized aircraft A7 x 19, 7.1 mm x 30.5 m (9/32" x 100")
- Recommended battery : 650 CCA minimum for winching
- Battery lead : 1.8 m (6') 6 gauge battery lead
- Mounting bolt pattern : Std. drum : 152.4 x 114 mm (6" x 4.5")
Long drum : 254 x 114 mm (10" x 4.5")
- Winch weight (including rope) : Std. drum : 22.8 kg / 50.3 lb
Long drum : 25.2 kg / 55.6 lb
- Gross weight : Std. drum : 28.4 kg / 62.6 lb ; Long drum : 32.8 kg / 72.3 lb
- Box dimension, (L x D x H) : Std. drum : 505 x 210 x 340 mm (19.9" x 8.3" x 13.4")
Long drum : 672 x 210 x 390 mm (26.5" x 8.3" x 15.4")

PERFORMANCE DATA :

Line Pull and Rope Capacity

Layer of Rope	Pull by Layer, kg / lb	Total Rope on the Drum, m / ft	
		Std. drum	Long drum
1 st	2,722 / 6,000	3.8 / 12.5	7 / 22.9
2 nd	2,266 / 4,995	8.4 / 27.5	15.4 / 50.4
3 rd	1,941 / 4,279	13.7 / 45	25.2 / 82.5
4 th	1,697 / 3,742	19.8 / 65.1	30.5 / 100
5 th	1,508 / 3,325	24.4 / 80	-

Line Speed and Amp. Draw (1st layer of wire rope on the drum)

Line Pull kg / lb	Line Speed, mpm / fpm	Amp. Draw, A 12V
No Load	8.0 / 26.2	60
907 / 2,000	5.2 / 17	150
1,814 / 4,000	3.1 / 10.2	240
2,722 / 6,000	2.0 / 6.5	300

DIMENSION mm/in : (DV-6 Std. drum)

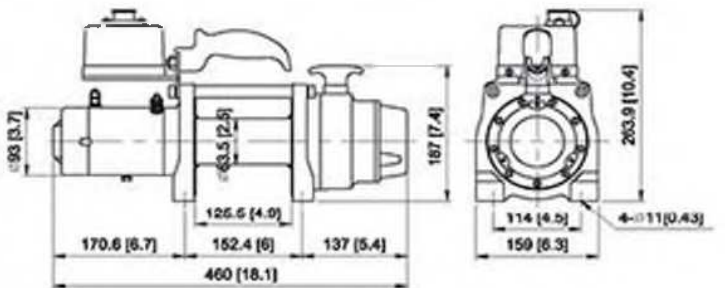

(DV-6 Long drum)

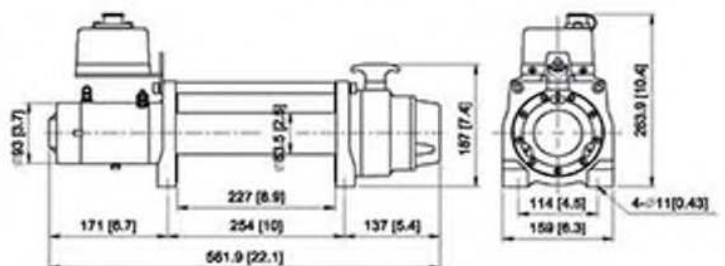

DV-6s/6s carry on

6,000 LB Electric Winch

DV-6s PN 854752 12V (with synthetic rope, hawse fairlead, remote control)

DV-6s carry on PN 854765 12V (with synthetic rope, hawse fairlead, remote control, 2" hitch receiver)



SPECIFICATIONS :

Rated line pull : 2,722 kg (6,000 lb) single line

Motor : 2,390 w / 3.2 hp, 12V series wound

Gear train & ratio : 3-stage planetary 216:1

Clutch (freespooling) : Rotating ring gear

Brake (outside the drum) : Automatic, full load CBS (Cone Brake Structure)

Winch construction : Aluminum die cast housings and strong steel drum

Drum size : 63.5 x 125.5 mm (2.5" x 4.9")

Control : Waterproof remote w/5 m (17') cord

Rope : Synthetic rope, 8 mm x 24.4 m (5/16" x 80')

Recommended battery : 650 CCA minimum for winching

Battery lead : 1.8 m (6') 6 gauge battery lead

Mounting bolt pattern : 152.4 x 114 mm (6" x 4.5")

Winch weight (including rope) : DV-6s: 19 kg / 41.9 lb

DV-6s carry on: 22.8 kg / 50.3 lb

Gross weight : DV-6s: 21.6 kg / 47.6 lb ; DV-6s carry on: 27.4 kg / 60.4 lb

Box dimension, (L x D x H) :

DV-6s: 505 x 210 x 340 mm (19.9" x 8.3" x 13.4")

DV-6s carry on: 515 x 285 x 345 mm (20.3" x 11.2" x 13.6")

PERFORMANCE DATA :

Line Pull and Rope Capacity

Layer of Rope	Pull by Layer, kg / lb	Total Rope on the Drum, m / ft
1 st	2,722 / 6,000	3.5 / 11.3
2 nd	2,266 / 4,995	7.7 / 25.2
3 rd	1,941 / 4,279	12.6 / 41.5
4 th	1,697 / 3,742	18.4 / 60.3
5 th	1,508 / 3,325	24.4 / 80

Line Speed and Amp. Draw (1st layer of rope on the drum)

Line Pull kg / lb	Line Speed mpm / fpm	Amp. Draw, A 12V
No Load	8.1 / 26.5	60
907 / 2,000	5.3 / 17.3	150
1,814 / 4,000	3.1 / 10.3	240
2,722 / 6,000	2.0 / 6.6	300

DIMENSION mm/in : (DV-6s)

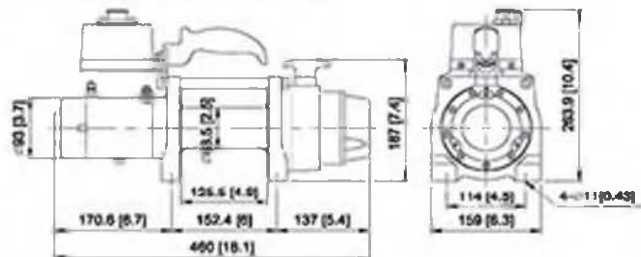

(DV-6s carry on)

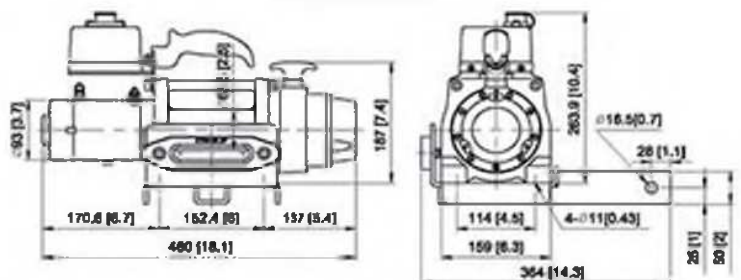



MadX

OUR FASTEST PLANETARY GEAR WINCH

***When your race motor can't get traction to the ground,
You need another high speed motor to pull you back on track.***

- ▶ Limited Lifetime Warranty for Mechanical Components.
- ▶ Three (3) Years Warranty for Electrical Components.



Seal MadX 8.0s

8,000 LB Extreme Racing Winch with 25mpm Line Speed

PN 296065 12V 10" Long Drum (with synthetic rope, hawse fairlead, remote control)



Note : Hawse fairlead does not mount to winch

SPECIFICATIONS :

Rated line pull : 3,630 kg (8,000 lb) single line
 Motor : 5,250 w / 7.0 hp, 12V series wound
 Gear train & ratio : 3-stage planetary 67:1
 Clutch (freespooling) : Rotating ring gear
 Brake (outside the drum) : Automatic, full load cone brake
 Winch construction : Aluminum die cast housings with steel drum
 Drum size : 63.5 x 227 mm (2.5" x 8.9")
 Control : Waterproof remote with thermometric indicator LED w/5 m (17') cord
 Rope : Synthetic rope, 10 mm x 30.5 m (3/8" x 100')
 Recommended battery : 650 CCA minimum for winching
 Battery lead : 1.8 m (6') 2 gauge battery lead
 Mounting bolt pattern : 254 x 114 mm (10" x 4.5")
 Winch weight (including rope) : 28 kg / 61.7 lb
 Gross weight : 40.5 kg / 89.1 lb
 Box dimension, (L x D x H) : 712 x 209 x 430 mm (28" x 8.2" x 16.9")

PERFORMANCE DATA :

Line Pull and Rope Capacity

Layer of Rope	Pull by Layer, kg / lb	Total Rope on the Drum, m / ft
1 st	3,630 / 8,000	5.8 / 19.1
2 nd	2,924 / 6,446	13.1 / 42.9
3 rd	2,449 / 5,399	21.7 / 71.2
4 th	2,106 / 4,643	30.5 / 100

Line Speed and Amp. Draw (1st layer of rope on the drum)

Line Pull kg / lb	Line Speed, mpm / fpm	Amp. Draw, A 12V
No Load	25 / 82	45
907 / 2,000	10.8 / 35.4	125
1,814 / 4,000	8.5 / 27.9	249
2,722 / 6,000	4.1 / 13.5	378
3,630 / 8,000	1.0 / 3.3	500



DIMENSION mm/In :

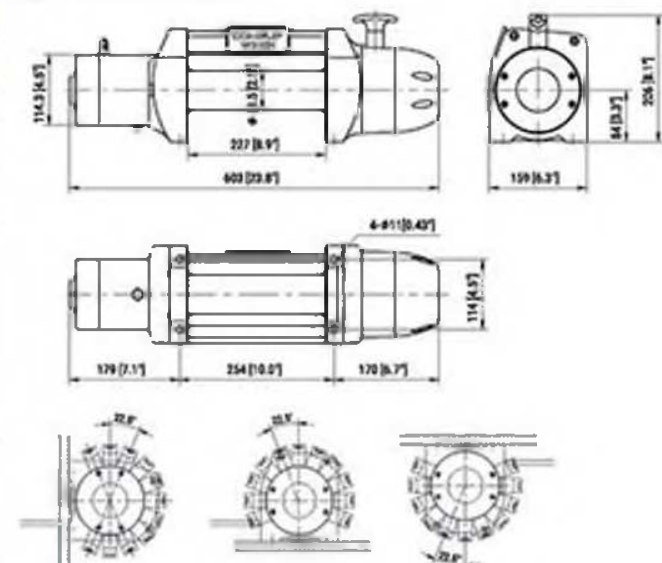

▶ 16 equally positioned pin holes ensure seamless clutch transmission and make it easily rotate by 22.5° increments.

**COMEUP
WINCH**

BLAZER M2/M3

Fastest retrieval speed up to 73 meter per minute for M3 /70 meter per minute for M2 (base on gear ratio at 28.0:1)

- 1 Powerful triple/twin 8.0 hp 12V series wound motors w/thermal protection switch provides ultimate power and high speed line pull.
- 2 Ratchet brake system located outside the drum greatly improves heat dispersion and is ideal for synthetic rope.
- 3 Personalized laser engraved driver or team namaplate and serial number for traceability.



- 4 Extreme rugged 3 stage spur gear train and upright housing.
- 5 The reinforced gearbox cover features a depiction of the northern Taiwan coastline, a symbol representing the high quality Made in Taiwan engineering and durability.
- 6 Three/Two submersible sealed contactors w/silver-alloy contact pads for proven reliability in extreme conditions and thick copper buss bars are built to handle the high amps and high duty cycles of racing use.
- 7 Dual braking system includes ratchet brake inside the gear box cover and air actuated brakes at each motor.
- 8 Race Team hawse fairlead designed to guide the synthetic rope out from and onto the winch drum.



- 9 Air free-spool control for rapid and easy synthetic rope payout. (Operation pressure: Fitting for M3 with 60 - 120 psi (4.1 ~ 8.3 bar) / M2 with 120 psi (8.3 bar).
- 10 Tough die cast aluminum alloy housings can withstand forces greater than 2 times the winch's rated capacity.

- 11 Laser engraved Blazer badge.



Optional

- Three different gear ratio -
 PN 883915 gear ratio kit 28.0 : 1
 PN 883916 gear ratio kit 33.6 : 1
 PN 883917 gear ratio kit 41.5 : 1
- Standard drum 285mm (11.2") /
 F11 883914 Replacing long drum kit 381 mm (15")



• Limited Lifetime Warranty for Mechanical Components.
 • One (1) Year Warranty for Electrical Components.

Blazer M2

8,000 LB Twin Motor Winch with 60mpm Line Speed

- PN 855910 12V (Std. drum / 33.6:1 gear ratio)
- PN 855905 12V (Long drum / 33.6:1 gear ratio)
- PN 855941 12V (Std. drum / 28.0:1 gear ratio)
- PN 855930 12V (Long drum / 28.0:1 gear ratio)
- PN 855923 12V (Std. drum / 41.5:1 gear ratio)
- PN 855917 12V (Long drum / 41.5:1 gear ratio)

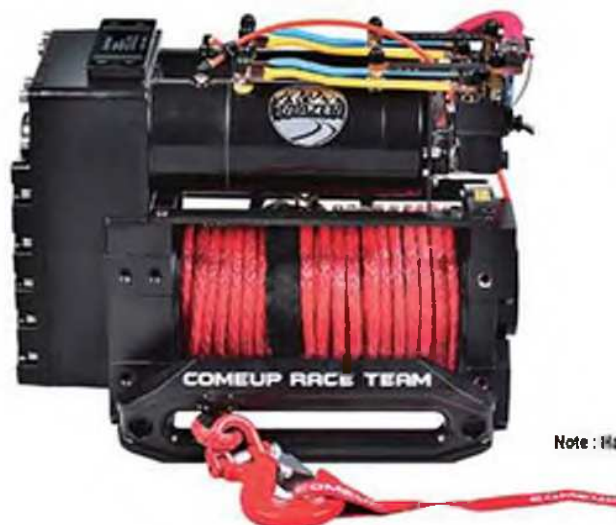

**TAIWAN
EXCELLENCE
2021**

Note : Hawse fairlead does not mount to winch

SPECIFICATIONS :

Rated line pull :

- 33.6:1 gear ratio - 3,630 kg (8,000 lb) single line
- 28.0:1 gear ratio - 2,722 kg (6,000 lb) single line
- 41.5:1 gear ratio - 4,535 kg (10,000 lb) single line

Line speed :

- 33.6:1 gear ratio - (1st layer) : 60 mpm / 197 fpm 110 A at 12V at no load
(5th layer) : 136 mpm / 446 fpm 110 A at 12V at no load
- 28.0:1 gear ratio - (1st layer) : 70 mpm / 229.7 fpm 110 A at 12V at no load
(5th layer) : 162 mpm / 531 fpm 110 A at 12V at no load
- 41.5:1 gear ratio - (1st layer) : 48 mpm / 157.5 fpm 110 A at 12V at no load
(5th layer) : 105 mpm / 344 fpm 110 A at 12V at no load

Motor : 6,000 w / 8.0 hp, 12V series wound x 2 pcs

Gear train : 3-stage spur gear train

Clutch (freespooling) : Air free-spooling

Brake (outside the drum) : Air brake system plus Ratchet brake

Winch construction : Aluminum die cast housings with steel drum

Drum size : 63.5 x 219 x 285 mm (2.5" x 8.6" x 11.2") - Std. drum
63.5 x 219 x 381 mm (2.5" x 8.6" x 15") - Long drum

Rope : Synthetic rope, 11 mm x 46 m (7/16" x 151') w/Sling hook

Recommended battery : 650 CCA minimum for winching

Battery lead : 1.8 m (6') 2/0 gauge battery lead

Mounting bolt pattern :

330 x 114.3 mm (13" x 4.5") ; 360 x 114.3 mm (14.2" x 4.5") - Std. drum
426 x 114.3 mm (16.8" x 4.5") ; 456 x 114.3 mm (18" x 4.5") - Long drum

Air pressure : 120 psi (8.3 bar)

Winch weight : 80 kg / 176.4 lb - Std. drum ; 86 kg / 189.6 lb - Long drum

Gross weight : 118 kg / 260.1 lb - Std. drum ; 128 kg / 282.2 lb - Long drum

Box dimension, (L x D x H) :

720 x 410 x 620 mm (28.3" x 16.1" x 24.4") - Std. drum
790 x 410 x 620 mm (31.1" x 16.1" x 24.4") - Long drum

STANDARD ACCESSORIES:

- Synthetic rope 11 mm x 46 m (7/16" x 151') w/ sling hook
- Hawse fairlead
- 1.8 m (6') 2/0 gauge battery lead

OPTION ACCESSORIES :

- Remote control w/ 5 m (17') cord
- Extra gear ratio kits

PERFORMANCE DATA :

Line Pull and Rope Capacity

Gear Ratio	28.0:1	33.6:1	41.5:1	Total Rope on the Drum, m / ft
	Pull by Layer, kg / lb			
1 st	2,722 / 6,000	3,630 / 8,000	4,535 / 10,000	5.8 / 19.0
2 nd	2,101 / 4,632	2,802 / 6,177	3,502 / 7,721	13.4 / 44.0
3 rd	1,711 / 3,772	2,282 / 5,031	2,852 / 6,288	22.7 / 74.5
4 th	1,443 / 3,181	1,925 / 4,244	2,405 / 5,302	33.6 / 110.2
5 th	1,248 / 2,751	1,664 / 3,669	2,080 / 4,586	46 / 151

Line Speed and Amp. Draw (1st layer of rope on the drum)

Line Pull	Line Speed (12V)					
	28.0:1		33.6:1		41.5:1	
Line Pull kg / lb	mpm / fpm	Amp. Draw	mpm / fpm	Amp. Draw	mpm / fpm	Amp. Draw
No Load	70 / 229.7	110	60 / 197	110	48 / 157.5	110
910 / 2,000	17.5 / 57.4	414	14.8 / 48.6	350	13.5 / 44.3	414
1,810 / 4,000	9.7 / 31.8	715	8.6 / 28.2	663	8.2 / 26.9	520
2,720 / 6,000	4.8 / 15.7	1,200	5.6 / 18.4	960	6.9 / 22.6	760
3,630 / 8,000	-	-	3.2 / 10.5	1,200	4.6 / 15.1	950
4,535 / 10,000	-	-	-	-	2.8 / 9.2	1,200

DIMENSION mm/in :

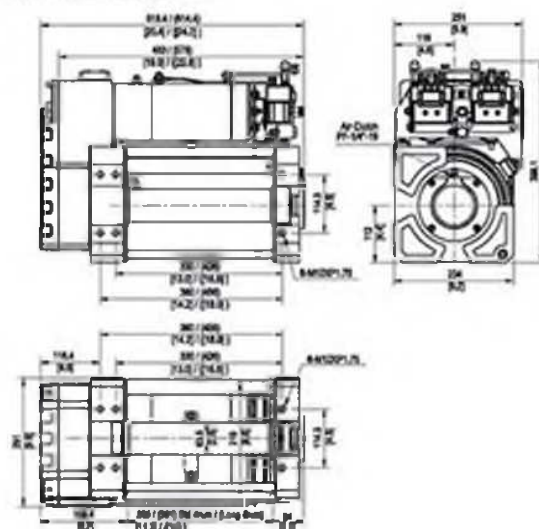

COMEUP WINCH

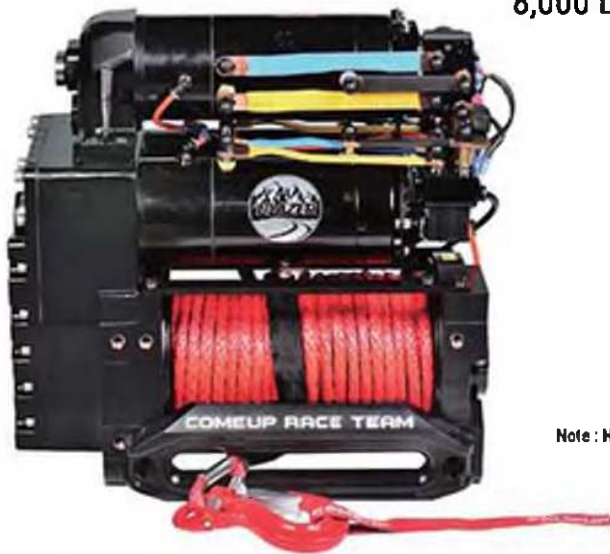

Blazer M3

8,000 LB Three Motors Winch with 63mpm Line Speed

- PN 855912 12V (Std. drum / 33.6:1 gear ratio)
- PN 855945 12V (Long drum / 33.6:1 gear ratio)
- PN 855928 12V (Std. drum / 28.0:1 gear ratio)
- PN 855921 12V (Long drum / 28.0:1 gear ratio)
- PN 855933 12V (Std. drum / 41.5:1 gear ratio)
- PN 855935 12V (Long drum / 41.5:1 gear ratio)



**TAIWAN
EXCELLENCE
2021**

Note : Hawse fairlead does not mount to winch

SPECIFICATIONS :

- Rated line pull :**
 33.6:1 gear ratio - 3,630 kg (8,000 lb) single line
 28.0:1 gear ratio - 2,722 kg (6,000 lb) single line
 41.5:1 gear ratio - 4,535 kg (10,000 lb) single line
- Line speed :**
 33.6:1 gear ratio - (1st layer) : 63 mpm / 206.7 fpm 140 A at 12V at no load
 (5th layer) : 145 mpm / 476 fpm 140 A at 12V at no load
 28.0:1 gear ratio - (1st layer) : 73 mpm / 239.5 fpm 140 A at 12V at no load
 (5th layer) : 173 mpm / 568 fpm 140 A at 12V at no load
 41.5:1 gear ratio - (1st layer) : 50 mpm / 164 fpm 140 A at 12V at no load
 (5th layer) : 112 mpm / 367 fpm 140 A at 12V at no load
- Motor :** 6,000 w / 8.0 hp, 12V series wound x 3 pcs
Gear train : 3-stage spur gear train
Clutch (freespooling) : Air free-spooling
Brake (outside the drum) : Air brake system plus Ratchet brake
Winch construction : Aluminum die cast housings with steel drum
Drum size : 63.5 x 219 x 285 mm (2.5" x 8.6" x 11.2") - Std. drum
 63.5 x 219 x 381 mm (2.5" x 8.6" x 15") - Long drum
Rope : Synthetic rope, 11 mm x 46 m (7/16" x 151') w/Sling hook
Recommended battery : 650 CCA minimum for winching
Battery lead : 1.8 m (6') 2/0 gauge battery lead
Mounting bolt pattern :
 330 x 114.3 mm (13" x 4.5") ; 360 x 114.3 mm (14.2" x 4.5") - Std. drum
 426 x 114.3 mm (16.8" x 4.5") ; 456 x 114.3 mm (18" x 4.5") - Long drum
Air clutch pressure : Fitting for with 60 - 120 psi (4.1 - 8.3 bar)
Winch weight : 95 kg / 209.4 lb - Std. drum ; 101 kg / 222.7 lb - Long drum
Gross weight : 134 kg / 295.4 lb - Std. drum ; 144 kg / 237.5 lb - Long drum
Box dimension, (L x D x H) :
 720 x 410 x 720 mm (28.3" x 16.1" x 28.3") - Std. drum
 790 x 410 x 720 mm (31.1" x 16.1" x 28.3") - Long drum

STANDARD ACCESSORIES :

- Synthetic rope 11 mm x 46 m (7/16" x 151') w/ sling hook
- Hawse fairlead
- 1.8 m (6') 2/0 gauge battery lead

OPTION ACCESSORIES :

- Remote control w/ 5 m (17') cord
- Extra gear ratio kits

PERFORMANCE DATA :

Line Pull and Rope Capacity

Gear Ratio	28.0:1	33.6:1	41.5:1	Total Rope on the Drum, m / ft
Layer of Ropa	Pull by Layer, kg / lb			
1 st	2,722 / 6,000	3,630 / 8,000	4,535 / 10,000	5.8 / 19.0
2 nd	2,101 / 4,632	2,802 / 6,177	3,502 / 7,721	13.4 / 44.0
3 rd	1,711 / 3,772	2,282 / 5,031	2,852 / 6,288	22.7 / 74.5
4 th	1,443 / 3,181	1,925 / 4,244	2,405 / 5,302	33.6 / 110.2
5 th	1,248 / 2,751	1,664 / 3,669	2,080 / 4,586	46 / 151

Line Speed and Amp. Draw (1st layer of rope on the drum)

Line Pull	Line Speed (12V)					
	28.0:1		33.6:1		41.5:1	
Line Pull kg / lb	mpm / fpm	Amp. Draw	mpm / fpm	Amp. Draw	mpm / fpm	Amp. Draw
No Load	73 / 239.5	140	63 / 206.7	140	50 / 164	140
910 / 2,000	19.5 / 64	540	18.5 / 60.7	460	17.5 / 57.4	420
1,810 / 4,000	12.8 / 42	715	11.8 / 38.7	690	10.5 / 34.5	640
2,720 / 6,000	6.5 / 21.3	1,200	7.0 / 22.9	960	7.9 / 25.9	860
3,630 / 8,000	-	-	5.0 / 16.4	1,200	5.5 / 18.0	1,050
4,535 / 10,000	-	-	-	-	3.3 / 10.8	1,200

DIMENSION mm/in :

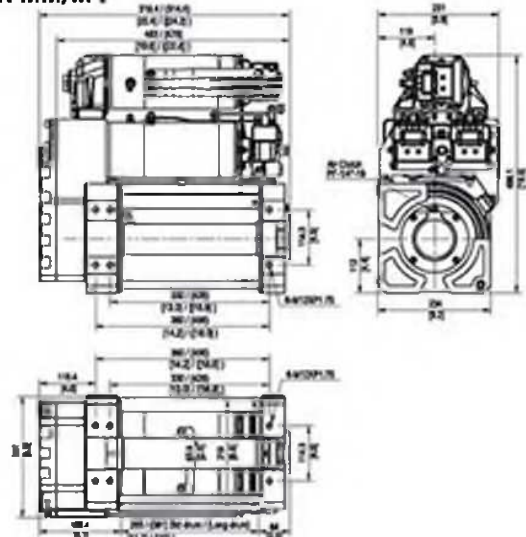

UTILITY DUTY WINCH

The Utility Duty winch series are designed to be a flexible tool for loading trailers or moving various vehicles or even boats into position. COMEUP Utility Winches provide line pull of 4,500 - 5,000 lb rating with power-out device for rapid wire rope payout. These multi-use units are easy to install and feature high torque, permanent magnet motors to deliver high line pull capacities at a lower amp draw. The dual braking effect of the automatic load holding brake and permanent magnet motor assures safe and reliable operation.

- Power In and Power out.
- High torque permanent magnet motor enables high line pull at lower amp and slip free dynamic brake.
- 3-stage planetary gearbox delivers the most reliable and durable performance of winch under the most rugged conditions.
- Sliding pin and ring gear clutch for rapid rope payout.
- Automatic load-holding mechanical brake plus motor dynamic brake ensure holding the load without slippage.
- Compact and light weight allows a wide range of application on trailers and boats.
- With circuit breakers to prevent motor overheating.
- Integrated solenoid pack for ease of installation and better protection of wiring.
- Standard Compliance:
 - CE Machinery Directive 2006/42/EC
 - CE Electromagnetic Compatibility Directive 2014/30/EU



- ▶ Limited Lifetime Warranty for Mechanical Components.
- ▶ One (1) Year Warranty for Electrical Components.

COMEUP WINCH

UW-5000si

5,000 LB Utility Duty Winch

PN 645010 12V (with wireless remote control, synthetic rope, hawse fairlead)



Convenient storage pocket for Transmitter



TAIWAN
EXCELLENCE
2019

SPECIFICATIONS :

Rated line pull : 2,268 kg (5,000 lb) single line
 Motor : 1,300 w / 1.7 hp, 12V permanent magnet
 Gear train & ratio : 3-stage planetary 170:1
 Clutch (freespooling) : Sliding ramping
 Brake : Mechanical spring applied brake plus permanent magnet motor dynamic brakes
 Drum size : 54 x 83 mm (2.1" x 3.3")
 Control : Wireless remote control and on board rocker switch control
 Rope : Synthetic rope , 6.3 mm x 15.2 m (1/4" x 50')
 Recommended battery : 650 CCA minimum for winching
 Battery lead : 1.5 m (5') 6 gauge battery lead
 Mounting bolt pattern : 72 x 93 mm (2.8" x 3.7")
 Winch weight (including rope) : 12.7 kg / 28 lb
 Gross weight : 16.7 kg / 36.8 lb
 Box dimension, (L x D x H) : 462 x 271 x 185 mm (18.2" x 10.7" x 7.3")

Intelligence Dashboard (IDB) :



Vehicle Battery Life
 The Intelligence Dashboard (IDB) displays the battery condition of your vehicle.



Cable IN/OUT Rocker Switch
 Directly control cable IN/OUT on winch panel.



Cutout Switch
 To activate or deactivate the winch and also deactivate the wireless receiver to prevent parasitic draw.



Wireless Signal Strength
 The solid green LED on the wireless transmitter indicates good signal strength, but a flashing red LED indicates a weak signal.



Wireless Signal Icon
 The Intelligence Dashboard (IDB) includes a blue wireless signal icon that is continuously illuminated to confirm the wireless remote is paired with the winch.

PERFORMANCE DATA :

Line Pull and Rope Capacity

Layer of Rope	Pull by Layer, kg / lb	Total Rope on the Drum, m / ft
1 st	2,268 / 5,000	2.4 / 7.9
2 nd	1,876 / 4,136	5.3 / 17.4
3 rd	1,600 / 3,527	8.7 / 28.6
4 th	1,394 / 3,073	12.6 / 41.4
5 th	1,235 / 2,722	15.2 / 50

Line Speed and Amp. Draw (1st layer of rope on the drum)

Line Pull kg / lb	Line Speed, rpm / fpm	Amp. Draw, A 12V
No Load	5.5 / 18.0	25
454 / 1,000	5 / 16.4	75
907 / 2,000	3.6 / 11.8	140
1,361 / 3,000	2.5 / 8.2	210
1,814 / 4,000	1.4 / 4.6	310
2,268 / 5,000	1.0 / 3.3	360

DIMENSION mm/in :

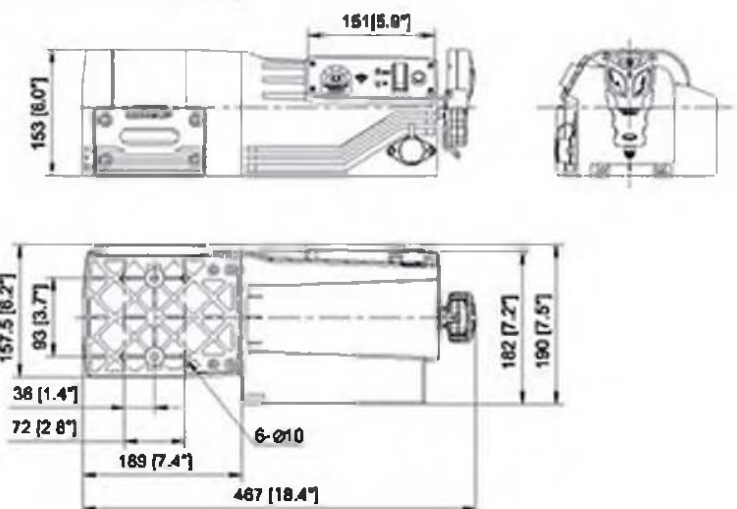

DV-4500i

4,500 LB Utility Duty Winch

PN 641656 12V | PN 642037 24V

SPECIFICATIONS :

Rated line pull : 2,041 kg (4,500 lb) single line

Motor : 1,200 w / 1.6 hp, 12V / 24V permanent magnet

Gear train & ratio : 3-stage planetary 170:1

Clutch (freespooling) : Sliding ramping

Brake : Mechanical spring applied and permanent magnet motor dynamic brakes together

Drum size : 54 x 83 mm (2.1" x 3.3")

Control : Handheld pendant switch remote control

Rope : Galvanized aircraft A7 x 19, 6.3 mm x 15.2 m (1/4" x 50')

Recommended battery : 650 CCA minimum for winching

Battery lead : 12V : 1.5 m (5') 6 gauge battery lead

24V : 1.5 m (5') 8 gauge battery lead

Mounting bolt pattern : 86 x 93 mm (3.4" x 3.7")

Winch weight (including rope) : 14.2 kg / 31.2 lb

Gross weight : 18.2 kg / 40 lb

Box dimension, (L x D x H) : 470 x 280 x 200 mm (18.5" x 11" x 7.9")



PERFORMANCE DATA :

Line Pull and Rope Capacity

Layer of Rope	Pull by Layer, kg / lb	Total Rope on the Drum, m / ft
1 st	2,041 / 4,500	2.4 / 7.9
2 nd	1,688 / 3,722	5.3 / 17.4
3 rd	1,440 / 3,174	8.7 / 28.6
4 th	1,255 / 2,766	12.6 / 41.4
5 th	1,112 / 2,451	15.2 / 50

Line Speed and Amp. Draw (1st layer of rope on the drum)

Line Pull kg / lb	Line Speed, mpm / fpm	Amp. Draw, A	
		12V	24V
No Load	6.5 / 21.3	25	10
454 / 1,000	5.0 / 16.4	110	55
907 / 2,000	3.6 / 11.8	210	95
1,134 / 2,500	3.2 / 10.5	240	110
1,361 / 3,000	2.5 / 8.2	270	120
1,588 / 3,500	1.8 / 5.9	290	140
1,814 / 4,000	1.4 / 4.6	310	155
2,041 / 4,500	0.4 / 1.3	330	170

DIMENSION mm/in :

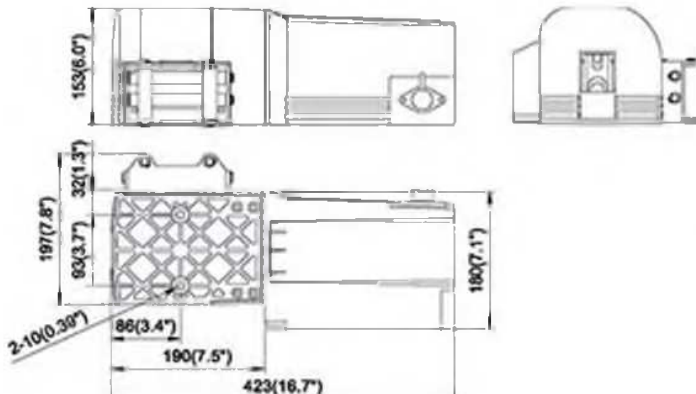

Entry-Level Electric Winch

G10 Series

8,000 - 10,000 - 12,000 lb pulling capacity

- 12V DC reliable recovery winch rated at 8,000 - 10,000 - 12,000 lb. pulling exceeds your expectations.
- Series-wound motor for power and fast line speed.
- Compact control pack fixed above motor for quick installation. It is also removable for various mounting options.
- Exclusive brake design with No. 37C device for better winching control.
- Durable, smooth, and reliable three-stage planetary gear train.
- Fine powder coated finish provides better weather resistance.
- Waterproof rated IP 68

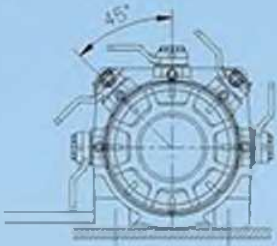

▶ 8 equally positioned pin holes ensure seamless clutch transmission and make it easily rotate by 45° increments. (G10 Series).



- ▶ Limited Lifetime Warranty for Mechanical Components.
- ▶ One (1) Year Warranty for Electrical Components.

GIO 120/120s

12,000 LB Electric Winch

GIO 120 PN 853832 12V (with wire rope, roller fairlead, remote control)

GIO 120s PN 853860 12V (with synthetic rope, hawse fairlead, remote control)



SPECIFICATIONS :

Rated line pull : 5,443 kg (12,000 lb) single line

Motor : 4,847 w / 6.5 hp 12V series wound

Gear train & ratio : 3-stage planetary, 234.6:1

Clutch (freespooling) : Rotating ring gear

Brake (inside the drum) : Exclusive brake design with No. 37C device

Winch construction : Aluminum die cast housings with steel drum

Drum size : 63.5 mm x 222.5 mm (2.5" x 8.8")

Control : Waterproof remote w/5 m (17') cord

Rope : GIO 120: Galvanized aircraft A7 x 19, 10.3 mm x 25.5 m (13/32" x 83.7')

GIO 120s: Synthetic rope, 11 mm x 25.5 m (7/16" x 83.7')

Recommended battery : 650 CCA minimum for winching

Battery lead : 1.8 m (6') 2 gauge battery lead

Mounting bolt pattern : 254 x 114 mm (10" x 4.5")

Winch weight (including rope) : GIO 120: 37.7 kg / 83.1 lb

GIO 120s: 35.2 kg / 77.6 lb

Gross weight : GIO 120: 52.7 kg / 116 lb

GIO 120s: 47.2 kg / 104.1 lb

Box dimension, (L x D x H) : 650 x 195 x 415 mm (25.6" x 7.7" x 16.3")

PERFORMANCE DATA :

Line Pull and Rope Capacity

Layer of Rope	Pull by Layer, kg / lb	Total Rope on the Drum, m / ft	
		GIO 120	GIO 120s
1 st	5,443 / 12,000	4.9 / 16.0	4.6 / 15
2 nd	4,188 / 9,233	11.1 / 36.4	10.5 / 34.4
3 rd	3,404 / 7,505	18.7 / 61.4	17.8 / 58.3
4 th	2,867 / 6,321	25.5 / 83.7	25.5 / 83.7

Line Speed and Amp. Draw (1st layer of rope on the drum)

Line Pull kg / lb	Line Speed, mpm / fpm	Amp. Draw, A 12V
No Load	7.8 / 25.6	45
1,361 / 3,000	4.5 / 14.6	110
2,722 / 6,000	4.0 / 13	165
4,082 / 9,000	3.5 / 11.4	220
5,443 / 12,000	2.7 / 8.9	340

DIMENSION mm/in :

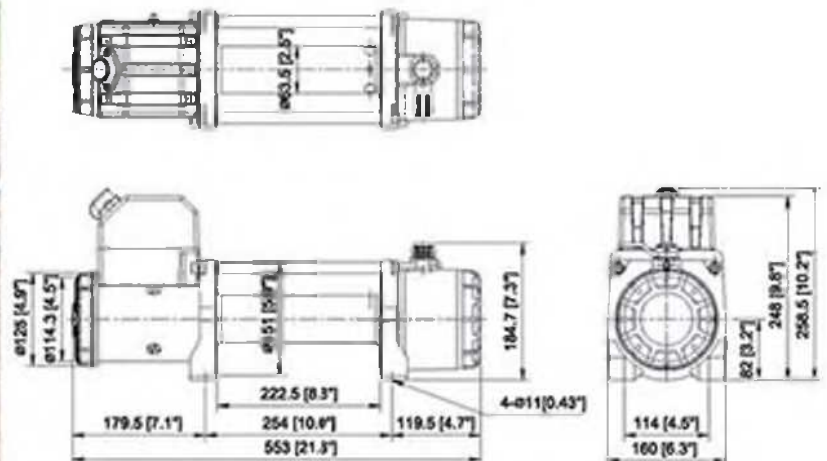

GIO 100/100s 10,000 LB Electric Winch

GIO 100 PN 853841 12V (with wire rope, roller fairlead, remote control)
GIO 100s PN 853839 12V (with synthetic rope, hawse fairlead, remote control)



SPECIFICATIONS :

Rated line pull : 4,535 kg (10,000 lb) single line
Motor : 4,101 w / 5.5 hp 12V series wound
Gear train & ratio : 3-stage planetary, 234.6:1
Clutch (freespooling) : Rotating ring gear
Brake (outside the drum) : Exclusive brake design with No. 37C device
Winch construction : Aluminum die cast housings with steel drum
Drum size : 63.5 mm x 222.5 mm (2.5" x 8.8")
Control : Waterproof remote w/5 m (17') cord
Rope : GIO 100: Galvanized aircraft A7 x 19, 9.5 mm x 26 m (3/8" x 85.3')
 GIO 100s: Synthetic rope, 10 mm x 26 m (3/8" x 85.3')
Recommended battery : 650 CCA minimum for winching
Battery lead : 1.8 m (6') 2 gauge battery lead
Mounting bolt pattern : 254 x 114 mm (10" x 4.5")
Winch weight (including rope) : GIO 100: 35.6 kg / 78.5 lb
 GIO 100s: 33.7 kg / 74.3 lb
Gross weight : GIO 100: 50.6 kg / 111.5 lb
 GIO 100s: 45.2 kg / 99.6 lb
Box dimension, (L x O x H) : 650 x 195 x 415 mm (25.6' x 7.7" x 16.3')

PERFORMANCE DATA :

Line Pull and Rope Capacity

Layer of Rope	Pull by Layer, kg / lb	Total Rope on the Drum, m / ft	
		GIO 100	GIO 100s
1 st	4,535 / 10,000	5.3 / 17.4	5.0 / 16.5
2 nd	3,598 / 7,932	11.9 / 39	11.4 / 37.4
3 rd	2,982 / 6,574	19.9 / 65.3	19.2 / 62.8
4 th	2,547 / 5,615	26 / 85.3	26 / 85.3

Line Speed and Amp. Draw (1st layer of rope on the drum)

Line Pull kg / lb	Line Speed, rpm / fpm	Amp. Draw, A 12V
No Load	8.3 / 27.2	45
1,134 / 2,500	4.0 / 13.1	120
2,268 / 5,000	3.3 / 10.9	200
3,402 / 7,500	3.1 / 10.3	260
4,535 / 10,000	2.9 / 9.5	310

DIMENSION mm/in :

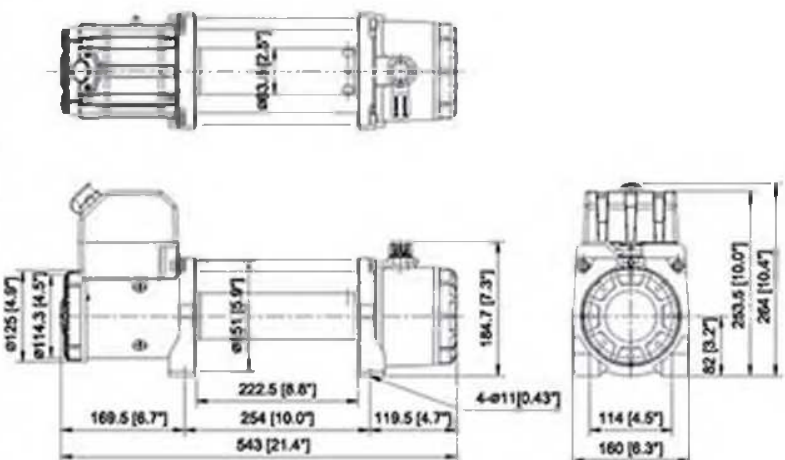

GIO 80/80s

8,000 LB Electric Winch

GIO 80 PN 853825 12V (with wire rope, roller fairlead, remote control)

GIO 80s PN 853818 12V (with synthetic rope, hawse fairlead, remote control)



SPECIFICATIONS :

Rated line pull : 3,630 kg (8,000 lb) single line

Motor : 3,356 w / 4.5 hp 12V series wound

Gear train & ratio : 3-stage planetary, 234.6:1

Clutch (freespooling) : Rotating ring gear

Brake (inside the drum) : Exclusive brake design with No. 37C device

Winch construction : Aluminum die cast housings with steel drum

Drum size : 63.5 mm x 222.5 mm (2.5" x 8.8")

Control : Waterproof remote w/5 m (17') cord

Rope : GIO 80: Galvanized aircraft A7 x 19, 8.3 mm x 29 m (21/64" x 95')

GIO 80s: Synthetic rope, 8 mm x 30.5 m (5/16" x 100')

Recommended battery : 650 CCA minimum for winching

Battery lead : 1.8 m (6') 2 gauge battery lead

Mounting bolt pattern : 254 x 114 mm (10" x 4.5")

Winch weight (including rope) : GIO 80: 32.9 kg / 72.5 lb

GIO 80s: 31 kg / 68.3 lb

Gross weight : GIO 80: 48.0 kg / 105.8 lb

GIO 80s: 43.3 kg / 95.5 lb

Box dimension, (L x D x H) : 650 x 195 x 415 mm (25.6" x 7.7" x 16.3")

PERFORMANCE DATA :

Line Pull and Rope Capacity

Layer of Rope	Pull by Layer, kg / lb	Total Rope on the Drum, m / ft	
		GIO 80	GIO 80s
1 st	3,630 / 8,000	5.9 / 19.5	6.1 / 20.0
2 nd	2,948 / 6,500	13.2 / 43.4	13.6 / 44.6
3 rd	2,482 / 5,472	21.7 / 71.9	22.5 / 73.8
4 th	2,143 / 4,725	29 / 95	30.5 / 100

Line Speed and Amp. Draw (1st layer of rope on the drum)

Line Pull kg / lb	Line Speed, mpm / fpm	Amp. Draw, A 12V
No Load	8.3 / 27.2	45
907 / 2,000	4.1 / 13.6	110
1,814 / 4,000	3.3 / 10.7	165
2,722 / 6,000	3.0 / 9.8	220
3,630 / 8,000	1.4 / 4.6	270

DIMENSION mm/in :

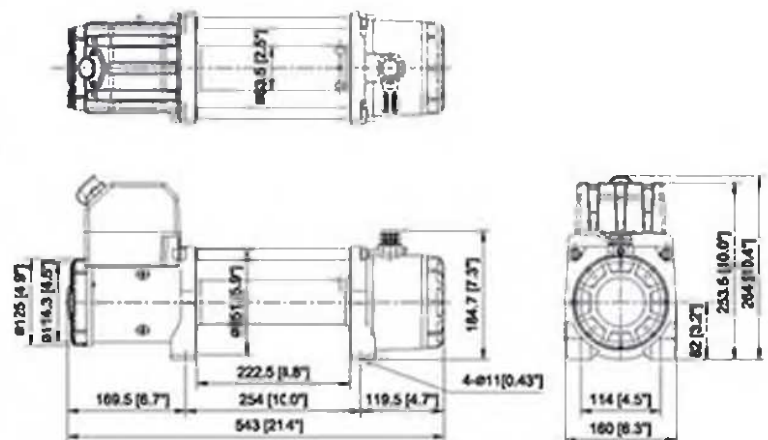

Wireless Remote Control

PN 883872 RF-24DP-C for automotive winches with a 6-pin plug

PN 883870 RF-24DP-A for automotive winches with a 3-pin plug

COMEUP wireless remote control communicates by a 2.4GHz digital transmission frequency. It delivers a reliable connection covering up to a 27m (90') radius without interference. Users will experience virtually no interference and no time-lag in operation even when multiple devices are used in the same working area. Two-way communication provides signal strength feedback and it requires no manual configuration. It's easy to install. Simple plug-and-play installation, the transmitter links up in seconds and stays linked automatically. Each pairing transmitter links up and stays linked automatically. You never have to worry about anyone having the same frequency.

- Works with any 12 or 24 volt contact-switched automotive winches.
- 2.4 GHz wireless technology works within 27m (90') radius and the anti-interference function lets you move around an obstacle for winching.
- Stylish and ergonomic design fits comfortably with your hand.
- Power is switched on after a 5-second continuous press for safety.
- Power is cut after 5-minutes of inactivity for safety and conserving battery life.
- The transmitter can be self-coded, simplifying installation and replacement.
- Meets International standards of CE Electromagnetic Compatibility Directive 2014/30/EU.
- This equipment has been tested and found to comply with the limits for a Class B digital device, pursuant to part 15 of the FCC Rules. These limits are designed to provide reasonable protection against harmful interference in a residential installation.



SPECIFICATIONS :

Frequency : 2.4 GHz

Remote range : up to 27 m (90')

LED Indication : Green light for power on.

Red light for winching.

Blinking green light for low battery life.

Blinking red light for poor signal received.

Transmitter : 3V lithium battery, weight: 60 g / 2.1 oz

Receiver : DC 8-24V rated 7.5A, weight: 150 g / 5.3 oz

WARRANTY : Each new wireless remote control is guaranteed against defects in workmanship and material defects for period of one (1) year from date of purchase.

DIMENSION mm/in :

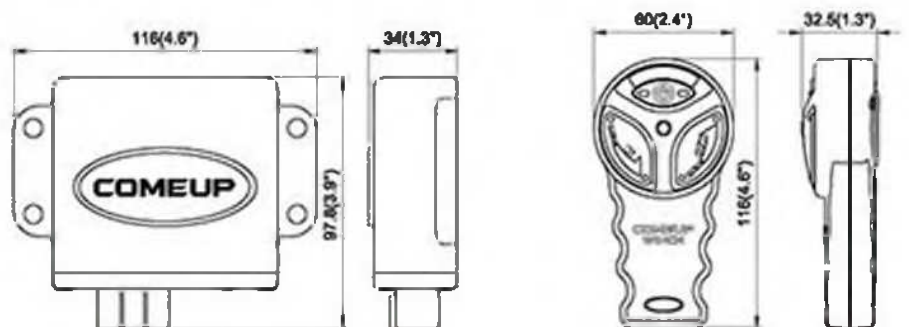

Medium Duty Kit **PN 883436**

Designed for winch single line capacity up to 4,309 kg / 9,500 lb

Includes :

- 10,000 kg / 22,000 lb maximum capacity snatch block, **PN 881079**
- 100 mm x 2.4 m (4" x 8') tree trunk protector strap, **PN 881091**
- 75 mm x 9 m (3" x 30') tow strap rated to 9,800 kg / 21,600 lb, **PN 881090**
- Bow shackle, 33 mm (3/4") pin diameter, **PN 883440**
- Gloves, **PN 883437**
- Bag, **PN 883439**



Heavy Duty Kit **PN 883438**

Designed for winch single line capacity up to 6,803 kg / 15,000 lb

includes :

- 13,610 kg / 30,000 lb maximum capacity snatch block, **PN 881082**
- 100 mm x 2.4 m (4" x 8') tree trunk protector strap, **PN 881091**
- 75 mm x 9 m (3" x 30') tow strap rated to 9,800 kg / 21,600 lb, **PN 881090**
- Bow shackle, 33 mm (3/4") pin diameter, **PN 883440**
- 3 m of 8 mm (10' of 5/16") grade 70 choker chain with hooks, **PN 881096**
- Gloves, **PN 883437**
- Bag, **PN 883439**



Automotive Winch Accessories

DC Solenoid

PN 881077 (12V) / PN 881078 (24V) for 4500i

Sealed Contactor

PN 881355 (12V) / PN 881356 (24V)

400A, for DV-9/9s/9i/9si/12 light/12s light/12/15/18, Seal Gen2 9.5/9.5s/9.5rs/9.5i/9.5si/9.5rsi/12.5/12.5s/12.5rs/16.5/16.5s/16.5rs/20.0/20.0s/20.0rs, Seal Slim 9.5rs/12.5rs, Seal MadX 8.0s, Walrus 18.0/22.0

PN 881357 (12V) 250A, for DV-6/6s/6s carry on

PN 883402 (12V) DES-S012 500A for Blazer M2/M3 and applicable for other brands of competition winches

PN 883422 (12V) Contactor Pack (Including DES-2012 250A w/lead) for Utility Winch 5000si

PN 883782 (12V) CES-4012VL-A 400A for GIO series

Remote Control

PN 880295 for DV-4500i

PN 880025 for DV-6/6s/6s carry on, GIO Series

PN 880126 for Seal Gen2 Series, Seal Slim

9.5rs/12.5rs, DV-9/9s/9i/9si/12 light/12s light/12/15/18, Seal MadX 8.0s (comes with protective thermal sensor LED)

PN 881671 for Walrus 18.0/22.0 (comes with protective thermal sensor LED & military quick connector)

Snatch Block

PN 881079 Max. load 10,000 kg / 22,000 lb for DV-6/6s/6s carry on, DV-9/9s/9i/9si, Seal Gen2 9.5/9.5s/9.5rs/9.5i/9.5si/9.5rsi, Seal Slim 9.5rs, Seal MadX 8.0s, Blazer M2/M3, GIO 80/80s/100/100s

PN 881080 Max. load 5,000 kg / 11,000 lb for DV-4500i, Utility Winch 5000si

PN 881082 Max. load 13,610 kg / 30,000 lb for Seal Gen2 12.5/12.5s/12.5rs, Seal Slim 12.5rs, DV-12/15, GIO 120/120s

PN 883866 Max. load 22,680 kg / 50,000 lb for DV-18, Seal Gen2 16.5/16.5s/16.5rs/20.0/20.0s/20.0rs, Walrus 18.0/22.0

Mounting Channel

PN 881083 Front mounting for DV-6 Long drum, DV-9/9s/9i/9si, Seal Gen2 9.5/9.5s/9.5rs/9.5i/9.5si/9.5rsi

PN 881085 Front mounting channel for DV-12/15

PN 882264 2" hitch receiver for DV-6s carry on

PN 884026 U-Type bracket for Detachable Control Box

Quick Connector

PN 881076 175A

Rope Stopper

PN 883399 for 10/11 mm diameter synthetic rope to protect the fairlead

Synthetic Rope

PN 883676 w/o hook for Seal Gen2 20.0s/20.0rs

- 16.7m (55') of 14 mm (9/16") diameter synthetic rope designs for electric winches application with line pull of 9,072 kg (20,000 lb) or less

PN 883325 w/o hook for Seal Gen2 16.5s/16.5rs

- 25 m (82') of 12.7 mm (1/2") diameter synthetic rope designs for electric winches application with line pull of 7,484 kg (16,500 lb) or less

PN 883248 w/o hook for Seal Gen2 9.5s/9.5rs/9.5si/9.5rsi, DV-9s/9si, Seal MadX 8.0s, Seal Slim 9.5rs

- 30.5 m (100') of 10 mm (3/8") diameter synthetic rope designs for off-road winches application with line pull of 4,309 kg (9,500 lb) or less.

PN 883285 w/o hook for Seal Gen2 12.5s/12.5rs, DV-12s light, Seal Slim 12.5rs

- 25 m (82') of 11 mm (7/16") diameter synthetic rope designs for off-road winches application with line pull of 5,670 kg (12,500 lb) or less.

PN 883274 w/o hook for DV-6s/6s carry on

- 24.4 m (80') of 8 mm (5/16") diameter synthetic rope designs for portable winch application with line pull of 2,722 kg (6,000 lb) or less.

PN 883413 w/o hook for Utility Winch 5000si

- 15.2 m (50') of 6.3 mm (1/4") diameter synthetic rope design for utility duty winch application with line pull of 2,268 kg (5,000 lb) or less.

PN 883271 8 mm x 30.5 m (5/16" x 100') for GIO 80s

PN 883272 10 mm x 26 m (3/8" x 85.3') for GIO 100s

PN 883273 11 mm x 25.5 m (7/16" x 83.7') for GIO 120s

PN 883240 11 mm x 46 m (7/16" x 151') for Blazer M2/M3

Wire Rope

PN 881929 12.7 mm x 25 m (1/2" x 82') for DV-18

PN 882027 11.1 mm x 27.4 m (7/16" x 90') for Seal Gen2 16.5, DV-15

PN 882026 9.5 mm x 38 m (3/8" x 125') for DV-12

PN 881994 9.5 mm x 25 m (3/8" x 82') for Seal Gen2 12.5, DV-12 light

PN 881988 8.7 mm x 30.5 m (11/32" x 100') for Seal Gen2 9.5/9.5i

PN 881986 8.3 mm x 30.5 m (21/64" x 100') for DV-9

PN 881987 8.3 mm x 30.5 m (21/64" x 100') for DV-9i

PN 882367 7.1 mm x 24.4 m (9/32" x 80') for DV-6 Std. drum

PN 882414 7.1 mm x 30.5 m (9/32" x 100') for DV-6 Long drum

PN 883082 12.7 mm x 25 m (1/2" x 82'), 6 x 29 - IWRC (Breaking strength 126.4 kN) for Walrus 22.0

PN 883081 11.1 mm x 27 m (7/16" x 89'), 6 x 29 - IWRC (Breaking strength 100.7 kN) for Walrus 18.0

PN 883675 12.7 mm x 18 m (1/2" x 59'), 6 x 29 - IWRC (Breaking strength 126.4 kN) for Seal Gen2 20.0

PN 883211 8.3 mm x 29 m (21/64" x 95') for GIO 80

PN 883212 9.5 mm x 26 m (3/8" x 85.3') for GIO 100

PN 883213 10.3 mm x 25.5 m (13/32" x 83.7') for GIO 120

Wire Rope with Safety Hook

PN 880305 6.3 mm x 15.2 m (1/4" x 50') for DV-4500i



COMEUP WINCH

Hook

PN 882477 sling hook for Seal Gen2 9.5s/9.5rs/9.5sl/9.5rsi/12.5s/12.5rs/16.5s/16.5rs, DV-9s/9sl/12s light, Seal MadX 8.0s, Blazer M2/M3, Seal Slim 9.5s/12.5rs, Blazer M2/M3

PN 881996 1/2" clevis hook for DV-12/15/18, Seal Gen2 12.5/16.5/20.0, GIO 100s/120/120s

PN 881995 3/8" clevis hook for Seal Gen2 9.5/9.5l, DV-6/6s/6s carry on/9/9l, GIO 100

PN 881997 5/16" clevis hook for Utility Winch 5000sl, GIO 80/80s

PN 883677 sling hook for Seal Gen2 20.0s/20.0rs

PN 883009 1/2" clevis hook for Walrus 18.0/22.0



Bow Shackles

PN 883440 33 mm (3/4") pin diameter



Detachable Control Box

PN 881164 (12V) for DV-9/9s/12 light/12s light/12/15/18, Seal Gen2 9.5/9.5s/12.5/12.5s/16.5/16.5s/20.0/20.0s

PN 881165 (24V) for DV-9/9s/12 light/12s light/12/15/18

PN 882780 (12V) for Seal Gen2 9.5rs/12.5rs/16.5rs/20.0rs, w/built-in wireless receiver

PN 882242 (12V) with handle for DV-6s carry on

PN 882265 (12V) with handle for DV-6 Std. drum, DV-6s

PN 882398 (12V) for DV-6 Long drum

PN 883070 (12V) for Seal MadX 8.0s

PN 883579 (12V) for Seal Slim 9.5rs/12.5rs w/built-in wireless receiver & Cutout Switch

PN 883637 (12V) for GIO 80/80s/100/100s

PN 883638 (12V) for GIO 120/120s



Air Clutch

PN 883036 for Seal Slim 9.5rs/12.5rs, Seal MadX 8.0s.

Seal Gen2 9.5/9.5s/9.5rs/9.5l/9.5sl/9.5rsi/12.5/12.5s/12.5rs



Clutch Lever IGT

PN 883236 for Seal Gen2

9.5/9.5s/9.5rs/9.5l/9.5sl/9.5rsi/12.5/12.5s/12.5rs, Seal Slim 9.5rs/12.5rs

PN 883239 for Seal Gen2

16.5/16.5s/16.5rs/20.0/20.0s/20.0rs, Walrus 18.0/22.0



Cable Tensioner

PN 881087 204 mm for DV-12/15

PN 882038 184 mm for DV-18

PN 883091 254 mm for Walrus 22.0

PN 883090 204 mm for Walrus 18.0



Battery Isolation Switch

PN 881097 2 Position Off-On 12V 500 Amp for Seal Gen2/Seal Slim/DV Series Winch



Automotive Winch Accessories

Bridge Control Box

PN 881160 (12V) / **PN 881161** (24V)

for DV-9l/9sl

PN 882681 (12V) for Seal Gen2 9.5l/9.5sl

PN 882685 (12V) for Seal Gen2 9.5rsi w/built-in wireless receiver



Roller Fairlead

PN 880289 63 mm throat for DV-4500i

PN 880066 179 mm throat for DV-12/15/18, Seal Gen2 16.5/20.0

PN 880096 109 mm throat for DV-6 Std. drum

PN 880023 210 mm throat for DV-6 Long drum,

DV-9/9l/12 light, Seal Gen2 9.5/9.5l/12.5

PN 882990 179 mm throat for Walrus 18.0

PN 883088 229 mm throat for Walrus 22.0

PN 883222 203 mm throat for GIO 80/100/120



Hawse Fairlead

PN 883410 184 mm throat for Seal Gen2

9.5s/9.5rs/9.5sl/9.5rsi/12.5s/12.5rs/16.5s/16.5rs

/20.0s/20.0rs, DV-9s/9sl/12s light, Seal Slim

9.5rs/12.5rs

PN 882152 112 mm throat for DV-6s/6s carry on

PN 883187 275(W) x 25(H) mm throat for Blazer M2/M3

PN 883789 371(W) x 25(H) mm throat for Blazer

M2/M3 Long drum

PN 883411 69 mm throat for Utility Winch 5000sl

PN 883622 183 mm throat for GIO 80s/100s/120s



Elite Hawse Fairlead

PN 883714 184 mm throat for Seal MadX 8.0s LD (10")



Race Team Hawse Fairlead

PN 883042 82 mm throat for short drum winch with

6" mounting bolt pattern

PN 883043 133 mm throat for medium drum winch

with 8" mounting bolt pattern

PN 883067 184 mm throat for long drum winch with

10" mounting bolt pattern



Tow Strap

Use a tow strap to pull another vehicle or as a winch extension.

• 9,800 kg / 21,600 lb recovery strap 75 mm x 9 m (3" x 30") , **PN 881090**



Tree Trunk Protector Strap

This tree trunk protector strap is useful for connecting a winch wire rope to almost any anchor point, but is primarily designed to prevent damage to a live tree trunk.

• 13,610 kg / 30,000 lb tree trunk protector 100 mm x 2.4 m (4" x 8") , **PN 881091**



Emergency Stop Switch

PN 881668 400A



Automotive Winch Accessories

Walrus/Seal Gen2/Seal Slim/MadX/Blazer

Model Number	Walrus		Seal Gen2										Seal Slim		MadX	Blazer							
	22.0	18.0	20.0	20.0s	20.0rs	16.5	16.5s	16.5rs	12.5	12.5s	12.5rs	9.5	9.5s	9.5rs	9.5l	9.5sl	9.5rs	12.5rs	9.5rs	8.0s	M2	M3	
Rated line pull	lb	22,000	18,000	20,000			16,500			12,500			9,500			9,500		12,500	9,500	8,000	8,000	8,000	
Remote control		●	●	●	●	●	●	●	●	●	●	●	●	●	●	●	●	●	●	●	●	●	●
Control box	12V	-	●	●	●	●	●	●	●	●	●	●	●	●	●	●	●	●	●	●	●	●	●
	24V	●	●	●	●	●	●	●	-	-	-	-	-	-	-	-	-	-	-	-	-	-	-
Wire rope w/hook		●	●	●	-	-	●	-	●	-	●	-	●	-	●	-	●	-	●	-	●	-	●
Synthetic rope w/hook		-	-	-	●	●	-	●	●	-	●	●	-	●	●	-	●	●	●	●	●	●	●
Roller fairlead		●	●	●			●		●	-	-	●	-	-	●	-	-	-	-	-	-	-	-
Hawse fairlead		-	-	-	●	●	-	●	●	-	●	●	-	●	●	-	●	●	●	●	●	●	●
Circuit breaker		○	○	○	○	○	○	○	○	○	○	○	○	○	○	○	○	○	○	○	○	○	○
Battery lead		●	●	●	●	●	●	●	●	●	●	●	●	●	●	●	●	●	●	●	●	●	●
Handsaver strap		●	●	●	●	●	●	●	●	●	●	●	●	●	●	●	●	●	●	●	●	●	●
Cable tensioner		●	●	-	-	-	-	-	-	-	-	-	-	-	-	-	-	-	-	-	-	-	-
Snatch block		○	○	○	○	○	○	○	○	○	○	○	○	○	○	○	○	○	○	○	○	○	○
Mounting channel		-	-	-	-	-	-	-	-	-	-	-	-	-	-	-	-	○	○	-	-	-	-
Winch accessory kit		-	-	-	-	-	-	-	○	○	○	○	○	○	○	○	○	○	○	○	○	○	○
Wireless remote control		-	-	○	○	Built-in	○	○	Built-in	○	○	Built-in	○	○	Built-in	○	○	Built-in	Built-in	○	○	○	○
Rope stopper		-	-	-	-	-	-	-	○	○	-	○	○	-	○	○	○	○	○	○	○	○	○
Clutch lever kit		○	○	○	○	○	○	○	○	○	○	○	○	○	○	○	○	●	●	-	-	-	-
Air clutch		-	-	-	-	-	-	-	○	○	○	○	○	○	○	○	○	○	○	○	○	-	-

DV/Utility Duty Winch/ GIO

Model Number	DV-										Utility Winch		DV-	GIO							
	18	15	12	12 light	12s light	9	9s	9l	9sl	6	6s	6s carry on	5000sl	4500l	80	80s	100	100s	120	120s	
Rated line pull	lb	18,000	15,000	12,000	12,000		9,000	9,000	6,000			5,000	4,500	8,000	10,000		12,000				
Remote control		●	●	●	●	●	●	●	●	●	●	●	-	●	●	●	●	●	●	●	●
Control box	12V	●	●	●	●	●	●	●	●	●	●	●	Built-in	Built-in	●	●	●	●	●	●	●
	24V	●	●	●	●	●	●	●	●	-	-	-	-	Built-in	-	-	-	-	-	-	-
Wire rope w/hook		●	●	●	●	-	●	-	●	-	●	-	-	●	●	-	●	-	●	-	●
Synthetic rope w/hook		-	-	-	-	●	-	●	-	●	●	●	●	-	-	●	-	●	-	●	-
Roller fairlead		●	●	●	●	-	●	-	●	-	●	-	-	●	●	-	●	-	●	-	●
Hawse fairlead		-	-	-	-	●	-	●	-	●	●	●	●	-	-	●	-	●	-	●	-
Circuit breaker		○	○	○	○	○	○	○	○	○	○	○	●	●	○	○	○	○	○	○	○
Battery lead		●	●	●	●	●	●	●	●	●	●	●	●	●	●	●	●	●	●	●	●
Handsaver strap		●	●	●	●	●	●	●	●	●	●	●	●	●	●	●	●	●	●	●	●
Cable tensioner		○	○	○	-	-	-	-	-	-	-	-	-	-	-	-	-	-	-	-	-
Snatch block		-	○	○	○	○	○	○	○	○	○	○	○	○	○	○	○	○	○	○	○
Mounting channel		-	○	○	-	-	○	○	○	○	○	○	○	○	○	-	-	-	-	-	-
Winch accessory kit		-	○	○	○	○	○	○	○	○	○	○	○	○	○	○	○	○	○	○	○
Wireless remote control		○	○	○	○	○	○	○	○	○	○	○	Built-in	○	○	○	○	○	○	○	○
Rope stopper		-	-	-	-	○	-	○	-	○	-	-	-	-	-	-	-	-	○	-	○

● Means as a standard accessory / ○ Means as an option accessory



POWERSPORTS WINCH

Cub Series

2,000 - 3,000 - 4,000 lb pulling capacity

- 1 High efficiency, low amp. draw and sealed permanent magnet motor
- 2 Mechanical spring applied and permanent motor dynamic brake together
- 3 Full metal 3-stage planetary gear train for greater pulling force
- 1 Cam activated clutch device for rapid rope payout
- 5 Submersible sealed contactor handles high amps and allows higher duty cycle



COMEUP manufactures a complete line of powersports winches. COMEUP winches are always the best choice for a rider who needs help out of the mud, snow, ice or whatever obstacle stands in the way. Cub series winches are designed for endurance and reliability with features like a precision 3-stage planetary gear, center drum design, weather-sealed contactor, mechanical load holding, and easy-to-use handlebar rocker switch. If you are looking for a powerful Powersports winch to add versatility and dependability to your vehicle, we are confident we have what you want.

Standard Compliance:

CE Machinery Directive 2006/42/EC

CE Electromagnetic Compatibility Directive 2014/30/EU



▲ Limited Lifetime Warranty for Mechanical Components.
▲ One (1) Year Warranty for Electrical Components.



Cub 4s carry on 4,000 LB Powersports Portable Winch

PN 123930 12V (with wire rope, roller fairlead, remote control, 2" hitch receiver)



SPECIFICATIONS :

- Rated line pull : 1,814 kg (4,000 lb) single line
- Motor : 800 w / 1.0 hp, 12V permanent magnet
- Gear train & ratio : 3-stage planetary 191:1
- Clutch (freespooling) : Sliding pin and ring gear
- Brake : Mechanical spring applied and permanent magnet motor dynamic brakes together
- Winch construction : Aluminum die cast housings and drum
- Drum size : 55 x 119 mm (2.2" x 4.7")
- Control : Remote control w/3 m cord
- Rope : Synthetic rope, 5.5 mm x 15.2 m (7/32" x 50')
- Recommended battery : 550 CCA minimum for winching
- Battery lead : 1.8 m (6') 6 gauge battery lead
- Mounting bolt pattern : 76 x 168 mm (3" x 6.6")
- Winch weight (including rope) : 12.2 kg / 26.9 lb
- Gross weight : 19.1 kg / 42.1 lb
- Box dimension, (L x D x H) : 410 x 200 x 345 mm (16.1" x 7.9" x 13.6")

PERFORMANCE DATA :

Line Pull and Rope Capacity

Layer of Rope	Pull by Layer, kg / lb	Total Rope on the Drum, m / ft
1 st	1,814 / 4,000	4.0 / 13.2
2 nd	1,535 / 3,385	8.8 / 28.8
3 rd	1,331 / 2,933	14.2 / 46.7
4 th	1,174 / 2,588	15.2 / 50

Line Speed and Amp. Draw (1st layer of rope on the drum)

Line Pull kg / lb	Line Speed, mpm / fpm	Amp. Draw, A 12V
No Load	6.0 / 19.7	15
454 / 1,000	3.4 / 11.2	70
907 / 2,000	2.9 / 9.5	120
1,361 / 3,000	2.4 / 7.9	180
1,814 / 4,000	2.0 / 6.6	230



DIMENSION mm/in :

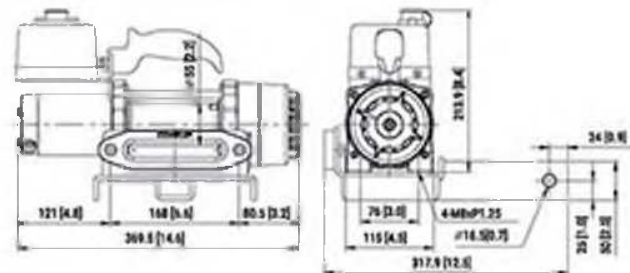

Standard Accessories

- ① Synthetic rope 5.5 mm x 15.2 m, PN 881993
- ② 2" hitch receiver, PN 882241
- ③ Clevis hook, PN 881997
- ④ Base plate bracket, PN 880269
- ⑤ Control box w/handle, PN 882239
- ⑥ Quick Connector wiring kit, PN 882252
- ⑦ Remote control w/3 m cord, PN 881305
- ⑧ Mounting hardware, PN 882369
- ⑨ Hawse fairlead, PN 881072

Cub 4/4s

4,000 LB Powersports Winch

Cub 4 PN 123920 12V (with wire rope, roller fairlead)

Cub 4s PN 129410 12V (with synthetic rope, hawse fairlead)



Note : Roller/Hawse fairlead does not mount to winch

SPECIFICATIONS :

- Rated line pull : 1,814 kg (4,000 lb) single line
- Motor : 800 w / 1.0 hp, 12V permanent magnet
- Gear train & ratio : 3-stage planetary 191:1
- Clutch (freespooling) : Sliding pin and ring gear
- Brake : Mechanical spring applied and permanent magnet motor dynamic brakes together
- Winch construction : Aluminum die cast housings and drum
- Drum size : 55 x 119 mm (2.2" x 4.7")
- Control : Handlebar rocker switch
- Rope : Cub 4 : Galvanized aircraft A7 x 19, 5.5 mm x 15.2 m (7/32" x 50')
Cub 4s : Synthetic rope, 5.5 mm x 15.2 m (7/32" x 50')
- Recommended battery : 550 CCA minimum (or winching)
- Battery lead : 1.8 m (6') 6 gauge battery lead
- Mounting bolt pattern : 76 x 168 mm (3" x 6.6")
- Winch weight (including rope) : Cub 4 : 8.9 kg / 19.6 lb
Cub 4s : 8 kg / 17.6 lb
- Gross weight : Cub 4 : 13.1 kg / 28.9 lb
Cub 4s : 12 kg / 26.4 lb
- Box dimension, (L x D x H) : 380 x 362 x 144 mm (15" x 14.3" x 5.7")

PERFORMANCE DATA :

Line Pull and Rope Capacity

Layer of Rope	Pull by Layer, kg / lb	Total Rope on the Drum, m / ft
1 st	1,814 / 4,000	4.0 / 13.2
2 nd	1,535 / 3,385	8.8 / 28.8
3 rd	1,331 / 2,933	14.2 / 46.7
4 th	1,174 / 2,588	15.2 / 50

Line Speed and Amp. Draw (1st layer of rope on the drum)

Line Pull, kg / lb	Line Speed, mpm / fpm	Amp. Draw, A 12V
No Load	6.0 / 19.7	15
227 / 500	3.9 / 12.8	45
454 / 1,000	3.4 / 11.2	70
680 / 1,500	3.1 / 10.2	90
907 / 2,000	2.9 / 9.5	120
1,134 / 2,500	2.7 / 8.9	150
1,361 / 3,000	2.4 / 7.9	180
1,588 / 3,500	2.2 / 7.2	210
1,814 / 4,000	2.0 / 6.6	230

DIMENSION mm/in :

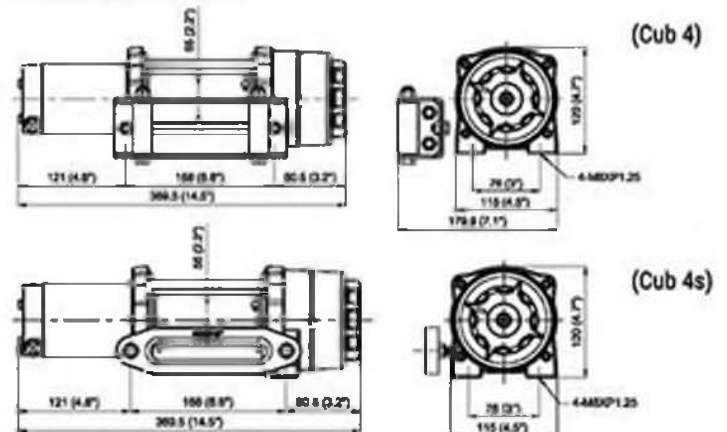

Cub 3/3s

3,000 LB Powersports Winch

Cub 3 PN 123561 12V (with wire rope, roller fairlead)

Cub 3s PN 129300 12V (with synthetic rope, hawse fairlead)



Note : Roller/Hawse fairlead does not mount to winch

SPECIFICATIONS :

Rated line pull : 1,361 kg (3,000 lb) single line

Motor : 800 w / 1.0 hp, 12V permanent magnet

Gear train & ratio : 3-stage planetary 138.5:1

Clutch (freespooling) : Sliding pin and ring gear

Brake : Mechanical spring applied and permanent magnet motor dynamic brakes together

Winch construction : Aluminum die cast housings and drum

Drum size : 55 x 75 mm (2.2" x 3")

Control : Handlebar rocker switch

Rope : Cub 3 : Galvanized aircraft A7 x 19, 4.8 mm x 15.2 m (3/16" x 50')

Cub 3s : Synthetic rope, 4.8 mm x 15.2 m (3/16" x 50')

Recommended battery : 550 CCA minimum for winching

Battery lead : 1.8 m (6') 6 gauge battery lead

Mounting bolt pattern : 76 x 124 mm (3" x 4.9")

Winch weight (including rope) : Cub 3 : 8.2 kg / 18 lb

Cub 3s : 7.2 kg / 15.9 lb

Gross weight : Cub 3 : 12.5 kg / 27.6 lb

Cub 3s : 11.5 kg / 25.3 lb

Box dimension, (L x D x H) : 349 x 331 x 144 mm (13.7" x 13" x 5.7")

PERFORMANCE DATA :

Line Pull and Rope Capacity

Layer of Rope	Pull by Layer, kg / lb	Total Rope on the Drum, m / ft
1 st	1,361 / 3,000	2.8 / 9.3
2 nd	1,173 / 2,585	6.1 / 20.1
3 rd	1,030 / 2,271	9.9 / 32.5
4 th	918 / 2,025	14.1 / 46.3
5 th	829 / 1,827	15.2 / 50

Line Speed and Amp. Draw (1st layer of rope on the drum)

Line Pull kg / lb	Line Speed, mpm / fpm	Amp. Draw, A 12V
No Load	6.8 / 22.2	25
227 / 500	5.7 / 18.7	45
454 / 1,000	4.8 / 15.6	75
680 / 1,500	3.8 / 12.5	105
907 / 2,000	3.0 / 9.8	140
1,134 / 2,500	2.5 / 8.0	180
1,361 / 3,000	2.0 / 6.7	230

DIMENSION mm/in :

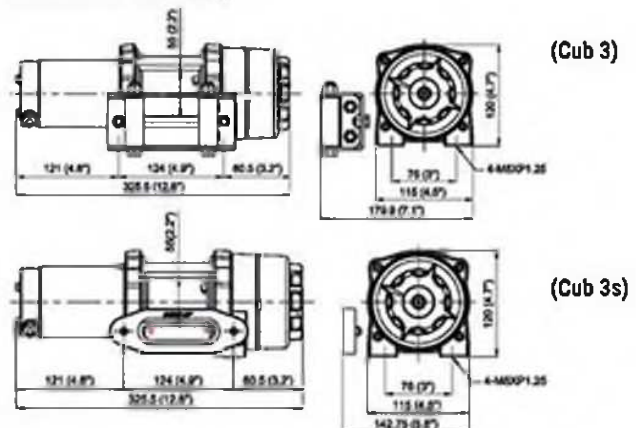

COMEUP WINCH

Cub 2/2s

2,000 LB Powersports Winch

Cub 2 PN 122012 12V (with wire rope, roller fairlead)

Cub 2s PN 122112 12V (with synthetic rope, hawse fairlead)



Note: Roller/Hawse fairlead does not mount to winch

SPECIFICATIONS :

- Rated line pull : 907 kg (2,000 lb) single line
- Motor : 600 w / 0.8 hp, 12V permanent magnet
- Gear train & ratio : 3-stage planetary 103:1
- Clutch (freespooling) : Cam activated
- Brake : Mechanical spring applied and permanent magnet motor dynamic brakes together
- Winch construction : Aluminum die cast drum and steel plate housings
- Drum size : 38 x 75 mm (1.5" x 3.0")
- Control : Handlebar rocker switch
- Rope : Cub 2 : Galvanized aircraft A7 x 19, 4 mm x 15.2 m (5/32" x 50')
Cub 2s : Synthetic rope, 4 mm x 15.2 m (5/32" x 50')
- Recommended battery : 550 CCA minimum for winching
- Battery lead : 1.8 m (6') 6 gauge battery lead
- Mounting bolt pattern : 76 x 124 mm (3" x 4.9")
- Winch weight (including rope) : Cub 2 : 6.5 kg / 14.3 lb
Cub 2s : 6 kg / 13.2 lb
- Gross weight : Cub 2 : 10 kg / 22 lb
Cub 2s : 9 kg / 19.8 lb
- Box dimension, (L x D x H) : 296 x 223 x 140 mm (11.7" x 8.8" x 5.5")

PERFORMANCE DATA :

Line Pull and Rope Capacity

Layer of Rope	Pull by Layer, kg / lb	Total Rope on the Drum, m / ft
1 st	907 / 2,000	2.4 / 7.9
2 nd	762 / 1,680	5.3 / 17.4
3 rd	657 / 1,448	8.6 / 28.2
4 th	577 / 1,272	12.4 / 40.7
5 th	515 / 1,135	15.2 / 50

Line Speed and Amp. Draw (1st layer of rope on the drum)

Line Pull kg / lb	Line Speed, mpm / fpm	Amp. Draw, A 12V
No Load	6.1 / 20.0	20
302 / 666	4.6 / 15.1	50
605 / 1,334	3.1 / 10.2	100
907 / 2,000	2.0 / 6.6	150

DIMENSION mm/in :

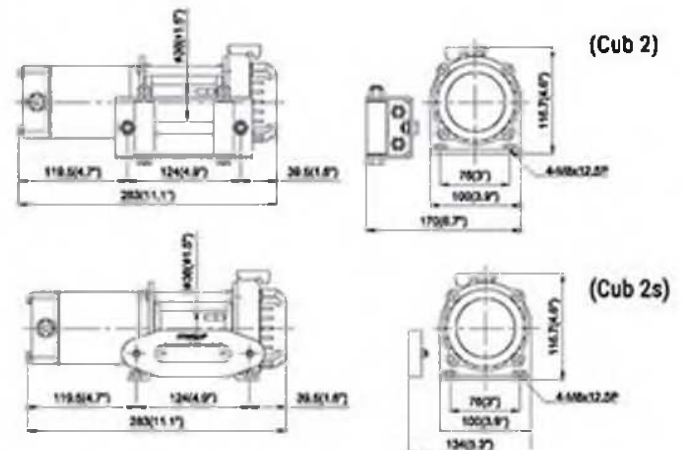

Powersports Winch Accessories

Wireless Remote Control

PN 883873 2.4 Ghz with 27 m (90'), RF-24DP D for Cub 2/2s/3/3s/4/4s

PN 883870 2.4 Ghz with 27 m (90'), RF-24DP A for Cub 4s carry on



Roller Fairlead

PN 880231 65 mm throat for Cub 2/3

PN 880132 109 mm throat for Cub 4



Hawse Fairlead

PN 881071 65 mm throat for Cub 2s/3s

PN 881072 108 mm throat for Cub 4s/4s carry on



Remote Control + Remote Socket

PN 881305 + PN 881004 for Cub 2/2s/3/3s/4/4s

PN 881305 for Cub 4s carry on



Contactors w/lead

PN 881385 250A, 12V for Cub 2/2s/3/3s/4/4s/4s carry on



Handlebar Switch Kit

PN 881003 Rocker switch with cord for Cub 2/2s/3/3s/4/4s



Contactors Pack

PN 881037 12V, Detachable contactor pack for Cub 2/2s/3/3s/4/4s



Snatch Block

PN 881080 Max. load 5,000 kg / 11,000 lb for Cub 4/4s/4s carry on

PN 881081 Max. load 2,722 kg / 6,000 lb for Cub 2/2s/3/3s



Wire Rope with Hook

PN 880257 4 mm x 15.2 m (5/32" x 50') w/stopper for Cub 2

PN 881954 4.8 mm x 15.2 m (3/16" x 50') w/stopper for Cub 3

PN 881955 5.5 mm x 15.2 m (7/32" x 50') w/stopper for Cub 4



Synthetic Rope

PN 881065 w/hook for Cub 2s

- 15.2 m (50') of 4 mm (5/32") diameter synthetic rope design for powersports winch application with line pull of 907 kg (2,000 lb) or less

PN 881952 w/hook for Cub 3s

- 15.2 m (50') of 4.8 mm (3/16") diameter synthetic rope design for powersports winch application with line pull of 1,361 kg (3,000 lb) or less

PN 881953 w/hook for Cub 4s

- 15.2 m (50') of 5.5 mm (7/32") diameter synthetic rope design for powersports winch application with line pull of 1,814 (4,000 lb) or less

- 15.2 m (50') of 5.5 mm (7/32") diameter synthetic rope design for powersports winch application with line pull of 1,814 kg (4,000 lb) or less



Hook

PN 881997 5/16" clevis hook for Cub 4s carry on



Quick Connector

PN 881075 50A, for Cub 2/2s/3/3s/4/4s/4s carry on



Powersports Winch Accessories Chart

Model Number		Cub 2	Cub 2s	Cub 3	Cub 3s	Cub 4	Cub 4s	Cub 4s carry on
Rated line pull	kg	907	907	1,361	1,361	1,814	1,814	1,814
	lb	2,000	2,000	3,000	3,000	4,000	4,000	4,000
Handlebar Switch Kit		●	●	●	●	●	●	-
Contactors Pack		●	●	●	●	●	●	-
Wire Rope w/Hook		●	-	●	-	●	-	-
Synthetic Rope w/Hook		-	●	-	●	-	●	●
Roller Fairlead		●	-	●	-	●	-	-
Hawse Fairlead		-	●	-	●	-	●	●
Handlebar Hardware		●	●	●	●	●	●	-
Mounting Hardware		●	●	●	●	●	●	●
Base Plate Kit		○	○	○	○	○	○	●
Handsaver Strap		●	●	●	●	●	●	●
Wireless Remote Control		○	○	○	○	○	○	○
Remote Control		○	○	○	○	○	○	●
Snatch Block		○	○	○	○	○	○	○

● Means as a standard accessory / ○ Means as an option accessory

INDUSTRIAL WINCH

HYDRAULIC RECOVERY WINCH

Powered by a PTO (power take off) unit driven pump, COMEUP Hydraulic Recovery Winches feature a commercial grade hydraulic system for hard working, industrial applications. These systems feature an extremely powerful and reliable hydraulic motor offering variable line speed for control when it's needed and high work rate to get the job done fast. The efficient and constant operating high torque motor supports professional applications in tough situations. COMEUP hydraulic Winches excel in a wide variety of applications including heavy duty vehicle recovery, heavy equipment loading, cargo loading along with many other commercial and industrial uses.

HYDRAULIC RECOVERY WINCH

▶ Bison Series 20,000 ~ 50,000 lb

▶ HV Series 8,000 ~ 15,000 lb

Features:

- Powered by an onboard hydraulic pump or PTO
- Fast and variable recovery speeds for high speed working
- Efficient and constant operating high torque motor
- 2-stage planetary gear train for greater pulling force
- Bison Series winches use air clutches.
- Drag brake and over-center valve providing complete braking
- EN 14492-1 supported: 10:1 D/d ratio and 2:1 wire rope strength allow severe duty vehicles and commercial recovery
- Meets SAE J706 revised AUG 2003, CE Machinery Directive 2006/42/EC, and EN 14492-1:2006 Power Driven Winches (Except Bison 30/50).



▶ One (1) year Warranty.

Bison Series

20,000 - 30,000 - 50,000 lb pulling capacity



- 1** Powered by a PTO (power take off unit) driven pump with variable recovery speeds for high working rate.
- 2** Highly efficient and constant operating torque motor.
- 3** Uses a patented Multi-Disc Brake (MDB) for safe and secure load holding
- 4** Hardened 2-stage planetary gear train provides faster line speeds.
- 5** Built-in air clutch for rapid wire rope payout

Remark : Low pressure motor or EN Version available upon request

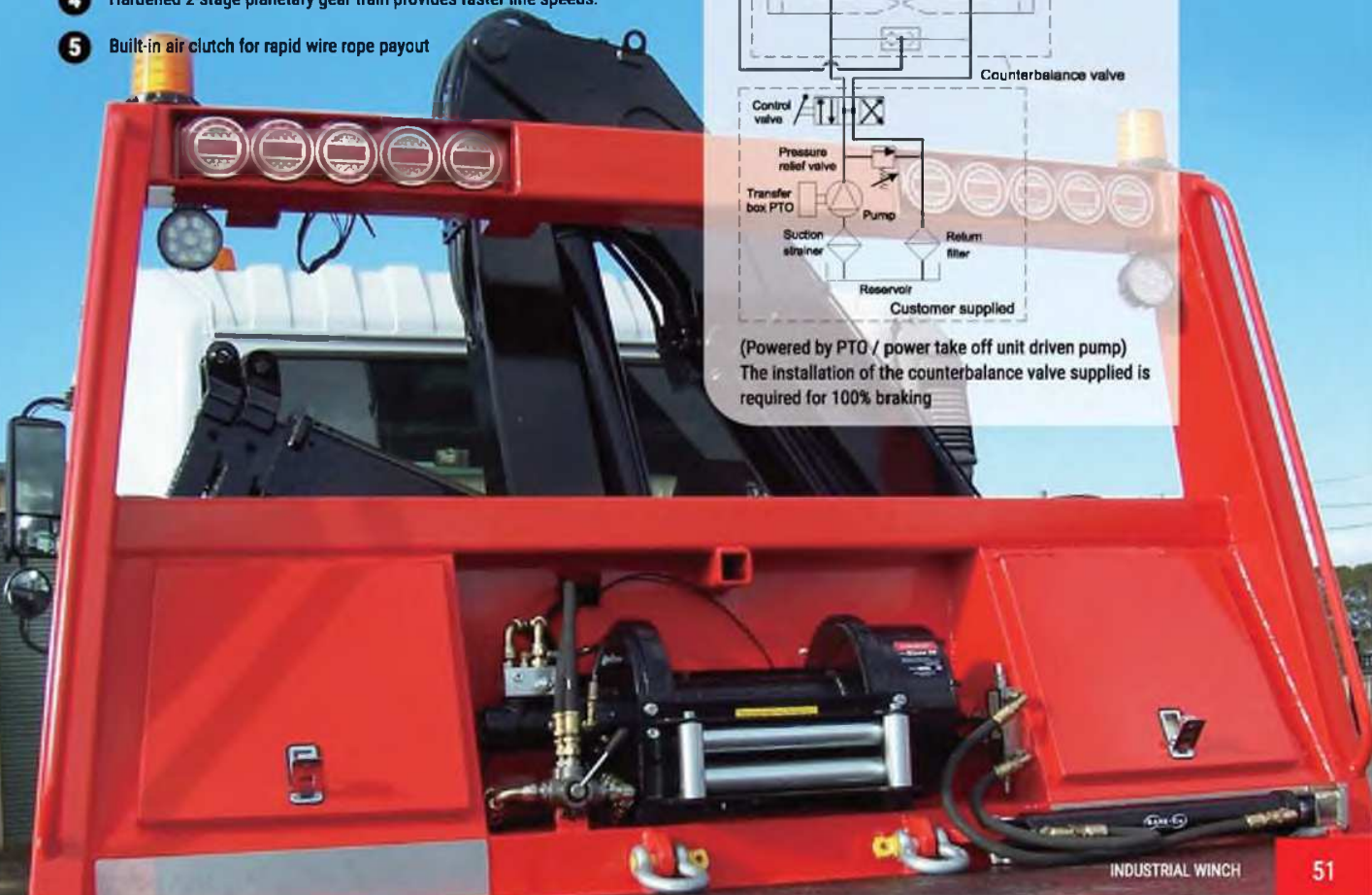
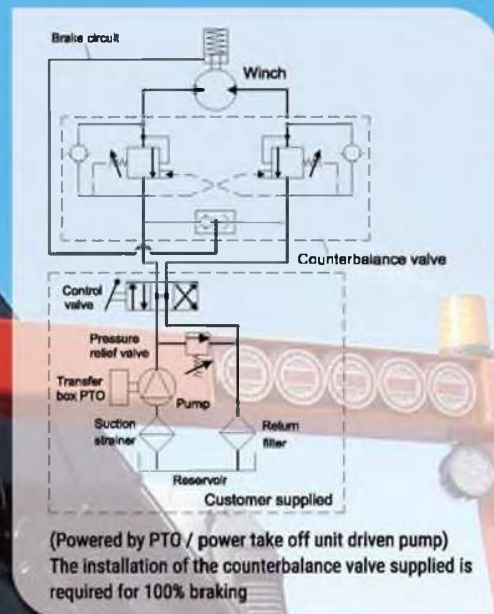



Note : Roller fairlead does not mount to winch

SPECIFICATIONS :

- Rated line pull : 22,680 kg (50,000 lb) SAE J706 ratings
- Operation pressure : 200 bar / 2,900 psi
- Max oil flow : 100 l/min (26.5 g/min)
- Hydraulic motor : 251.8 cm³ / rev (15.4 in³ / rev)
- Gear train & ratio : 2-stage planetary gear 44:1
- Winch construction : Cast housings with steel drum
- Clutch (Freespooling) : Output shaft disengaged
- Brake : Multi-Disc Brake (MDB) patented and counterbalance valve supplied
- Rotation of winch : Wire rope shall be under-wound orientation only
- Drum barrel diameter : 180 mm (7.1")
- Drum flange diameter : 406 mm (16")
- Distance between flanges : 368 mm (14.5")
- Mounting bolt pattern : 240 x 453 mm (9.5" x 17.8") ; 340 x 453 mm (13.4" x 17.8")
- Wire rope recommended : 22.4 mm x 48 m (7/8" x 157') 1,770 N/mm² (EIPS) breaking strength of 305 kN (68,566 lbf) required for SAE J706 ratings.
- Winch weight : 375 kg / 827 lb
- Gross weight : 410 kg / 904 lb
- Box dimension, (L x D x H) : 1,170 x 630 x 670 mm (46" x 24.8" x 26.4")

PERFORMANCE DATA :

Layer of Wire Rope	Line Pull and Rope Capacity		Line Speed
	Pull by Layer, kg / lb	Total Rope on the Drum, m / ft	at 100 l/min (26.5 g/min), mpm / fpm
1 st	22,680 / 50,000	10 / 33	5.7 / 19
2 nd	18,570 / 40,940	22 / 72	7.0 / 23
3 rd	15,720 / 34,660	36 / 118	8.3 / 27
4 th	13,630 / 30,050	48 / 157	9.6 / 31

DIMENSION mm/in :

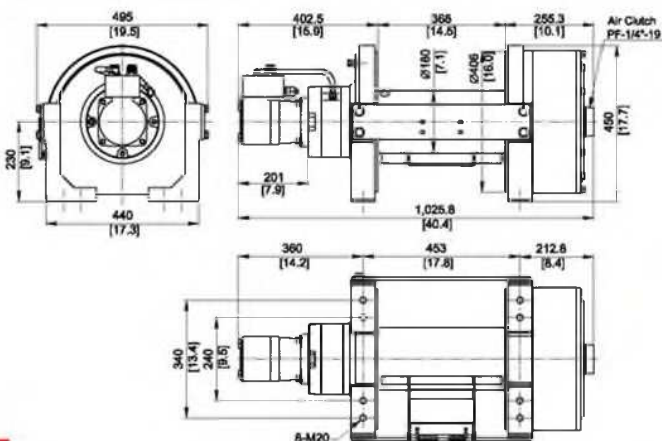

Bison 30

30,000 LB Hydraulic Recovery Winch

• Meets SAE J706 revised AUG2003, CE Machinery Directive 2006/42/EC
 PN 683030 Std. drum | PN 683352 Long drum



Note : Roller fairlead does not mount to winch

SPECIFICATIONS :

- Rated line pull : 13,600 kg (30,000 lb) SAE J706 ratings
- Operation pressure : 175 bar / 2,540 psi
- Max oil flow : 60 l/min (15.9 g/min)
- Hydraulic motor : 155.7 cm³ / rev (9.5 in³ / rev)
- Gear train & ratio : 2-stage planetary gear 41:1
- Winch construction : Cast housings with steel drum
- Clutch (Freespooling) : Output shaft disengaged
- Brake : Multi-Disc Brake (MDB) patented and counterbalance valve supplied
- Rotation of winch : Wire rope shall be under-wound orientation only
- Drum barrel diameter : 152.5 mm (6")
- Drum flange diameter : 343 mm (13.5")
- Distance between flanges : 203.2 mm (8") - Std. drum; 355.6 mm (14") - Long drum
- Mounting bolt pattern :
 - Std. drum - 190.5 x 304.8 mm (7.5" x 12"); 266.7 x 304.8 mm (10.5" x 12")
 - Long drum - 190.5 x 457.2 mm (7.5" x 18"); 266.7 x 457.2 mm (10.5" x 18")
- Wire rope recommended : 16 mm x 43 m (5/8" x 141') for Std. drum and 75 m (246') for Long drum, 1,960 N/mm² (EIPS) grade with a minimum breaking strength of 179 kN (40,167 lbf) required for SAE J706 ratings.
- Winch weight : 175 kg / 386 lb (Std. drum); 197 kg / 434 lb (Long drum)
- Gross weight : 198 kg / 437 lb (Std. drum); 235 kg / 518 lb (Long drum)
- Box dimension , (L x D x H) : 900 x 510 x 530 mm (35.4" x 20.1" x 20.9") - Std. drum
 1,040 x 620 x 510 mm (40.9" x 24.4" x 20.1") - Long drum

PERFORMANCE DATA :

Layer of Wire Rope	Line Pull and Rope Capacity		Line Speed	
	Pull by Layer, kg / lb	Total Rope on the Drum, m / ft	at 60 l/min (15.9 g/min), mpm / fpm	
1 st	13,600 / 30,000	6 / 20 11 / 36	5.0 / 16	
2 nd	11,438 / 25,216	14 / 44 25 / 82	5.9 / 19	
3 rd	9,864 / 21,745	22 / 73 40 / 131	6.9 / 23	
4 th	8,670 / 19,115	32 / 104 58 / 190	7.8 / 26	
5 th	7,735 / 17,052	43 / 141 75 / 246	8.8 / 29	

DIMENSION mm/in :

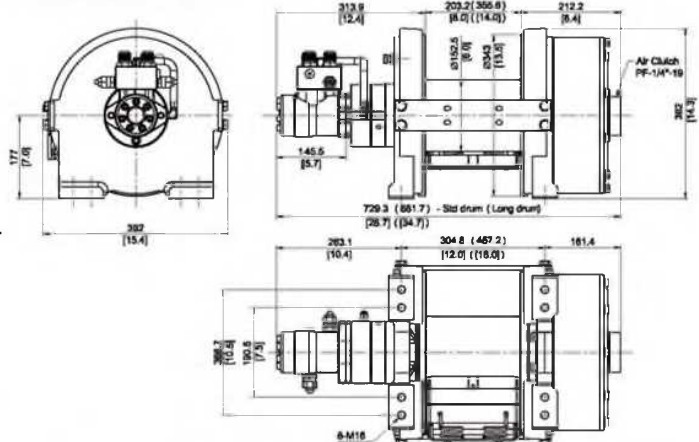

20,000 LB Hydraulic Recovery Winch

• Meets SAE J706 revised AUG2003, CE Machinery Directive 2006/42/EC and EN 14492-1:2006 Power Driven Winches

PN 682030 Std. dum | PN 682169 Long dum

**EN 14492-1
COMPLIANT**



Note : Roller fairlead does not mount to winch

SPECIFICATIONS :

Rated line pull : 9,070 kg (20,000 lb) EN 14492-1 rating & SAE J706 rating

Operation pressure : 175 bar / 2,540 psi

Max oil flow : 60 l/min (15.9 g/min)

Hydraulic motor : 155.7 cm³ / rev (9.5 in³ / rev)

Gear train & ratio : 2-stage planetary gear 30:1

Winch construction : Cast housings with steel drum

Clutch (Freespooling) : Output shaft disengaged

Brake : Multi-Disc Brake (MDB) patented and counterbalance valve supplied

Rotation of winch : Wire rope shall be under-wound orientation only

Drum barrel diameter : 146 mm (5.8")

Drum flange diameter : 314 mm (12.4")

Distance between flanges : 203.2 mm (8") - Std. drum ; 355.6 mm (14") - Long drum

Mounting bolt pattern :

Std. drum - 190.5 x 304.8 mm (7.5" x 12") ; 266.7 x 304.8 mm (10.5" x 12")

Long drum - 190.5 x 457.2 mm (7.5" x 18") ; 266.7 x 457.2 mm (10.5" x 18")

Wire rope recommended :

* 16 mm x 30 m for Std. drum and 55 m for Long drum, 1,960 N/mm² grade with a minimum breaking strength of 179 kN required for EN 14492-1 rating.

* 9/16" x 141' for Std. drum and 262' for Long drum, EIPS grade with a minimum breaking strength of 30,472 lbf required for SAE J706 rating.

Winch weight : 135 kg / 298 lb (Std. drum) ; 150 kg / 331 lb (Long drum)

Gross weight : 165 kg / 364 lb (Std. drum) ; 195 kg / 430 lb (Long drum)

Box dimension, (L x D x H) : 870 x 500 x 510 mm (34.3" x 19.7" x 20.1") - Std. drum
1,025 x 500 x 510 mm (40.4" x 19.7" x 20.1") - Long drum

PERFORMANCE DATA :

Layer of Wire Rope	Pull by Layer, kg / lb	Line Pull and Rope Capacity				Line Speed at 60 l/min (15.9 g/min) mpm / fpm		
		Total Rope on the Drum, m / ft		Std. drum			Long drum	
		14 mm rope	16 mm rope	14 mm rope	16 mm rope			
1 st	9,070 / 20,000	7 / 23	6 / 20	12 / 39	11 / 36	7.1 / 23		
2 nd	7,719 / 17,017	15 / 49	13 / 43	27 / 89	24 / 79	8.3 / 27		
3 rd	6,719 / 14,813	24 / 79	21 / 69	43 / 141	39 / 128	9.5 / 31		
4 th	5,948 / 13,113	34 / 112	30 / 98	62 / 203	55 / 180	10.8 / 35		
5 th	5,335 / 11,762	43 / 141	-	80 / 262	-	12 / 39		

DIMENSION mm/in :

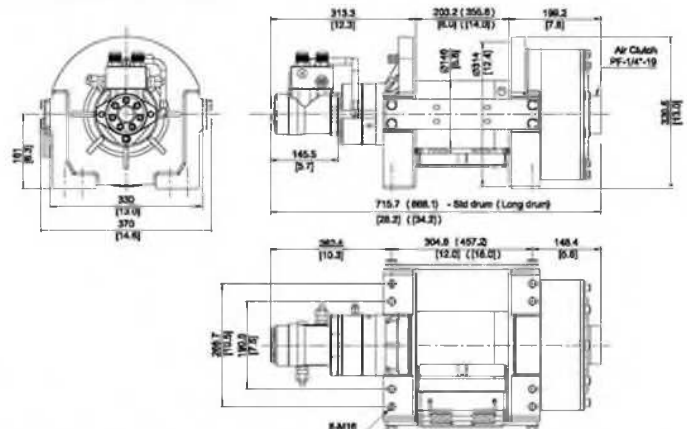

HV Series

8,000 - 10,000 - 12,000 - 15,000 lb pulling capacity

• Meets SAE J706 revised AUG2003, CE Machinery Directive 2006/42/EC, and EN 14492-1:2006 Power Driven Winches.



Note : Roller fairlead does not mount to winch. Clutch in left side.

**EN 14492-1
COMPLIANT**

- 1 Powered by a PTO Device**
Adjustable oil flow and pressure allow variable line pull and speed.
- 2 Extreme Motor**
Highly efficient and constant operating torque output.
- 3 Doubled Failsafe Brakes**
Mechanical drag brake and over-center valve provided for holding full load.
- 4 Outstanding and Elegant Design**
Aluminum die cast housings with steel drum.
- 5 2-stage Planetary Gear Train**
Less gear reduction ratio for maximum rated line speed.
- 6 Turn Clutch by Ergonomic T-handle for Rapid Wire Rope Payout**
Easy to turn the T-handle for rapid wire rope payout and workable for left or right side location.

Compliant with EN 14492-1 requirements for recovery winch:
 * The working coefficient for the first rope layer on the drum shall be at least 2.
 * The D/d ratio to the center of the rope shall be at least 10 for the drum.
 * Drum freeboard shall be at least 1.5 x rope diameter.

Hydraulic System Installation
(Powered by a PTO/power take off unit driven pump)

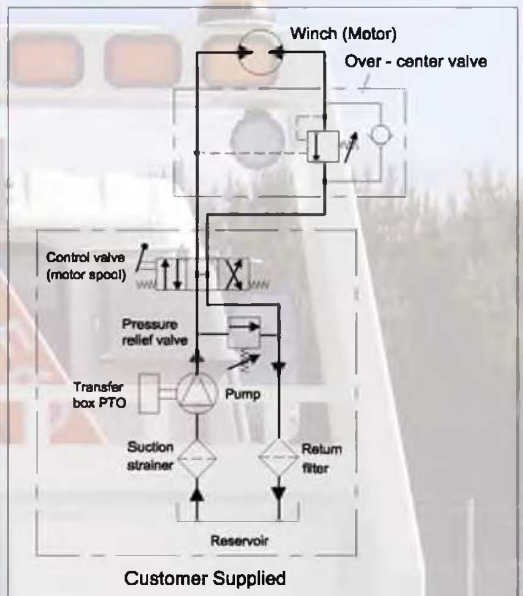

Advantage: Professional winch system for hard working applications is cost effective, extremely powerful, reliable, light weight, and feature variable line speed for a high work rate.

15,000 LB Hydraulic Recovery Winch

• Meets SAE J706 revised AUG2003, CE Machinery Directive 2006/42/EC and EN 14492-1: 2006 Power Driven Winches
PN 686732 Std. drum | PN 687548 Std. drum, Clutch in left side



Note : Roller fairlead does not mount to winch

SPECIFICATIONS :

Rated line pull : 6,800 kg (15,000 lb) EN 14492-1 rating & SAE J706 rating
Operation pressure : 150 bar / 2,175 psi
Max oil flow : 60 l/min (15.9 g/min)
Hydraulic motor : 156 cm³ / rev (9.5 in³ / rev)
Gear train & ratio : 2-stage planetary 19.4:1
Winch construction : Aluminum die cast housings with steel drum
Clutch (freespooling) : Rotating ring gear
Brake : Spring applied drag brake together with over-center valve supplied
Rotation of winch : Wire rope shall be under-wound orientation only
Drum barrel diameter : 127 mm (5.0")
Drum flange diameter : 252 mm (9.9")
Drum between flanges : 255 mm (10.0")
Mounting bolt pattern :
 303.5 x 114.3 mm (12.0" x 4.5"); 368.5 x 171.2 mm (14.5" x 6.7")
Wire rope recommended :
 14 mm x 27 m (9/16" x 89'), 1,960 N/mm² (EIPS) grade with a minimum breaking strength of 137 kN (30,742 lbf) required for SAE J706 and EN 14492-1 ratings
Winch weight : 72 kg / 158.7 lb
Gross weight : 88 kg / 194 lb
Box dimension, (L x D x H) : 735 x 430 x 335 mm (29" x 16.9" x 13.2")

PERFORMANCE DATA :

Layer of Wire Rope	Line Pull and Rope Capacity		Line Speed
	Pull by Layer, kg / lb	Total Rope on the Drum, m / ft	at 60 l/min (15.9 g/min), mpm / fpm
1 st	6,800 / 15,000	7.8 / 25.6	9.0 / 30.0
2 nd	5,637 / 12,507	17.3 / 56.8	10.5 / 34.4
3 rd	4,867 / 10,507	27.0 / 89.0	12.3 / 40.4

DIMENSION mm/in :

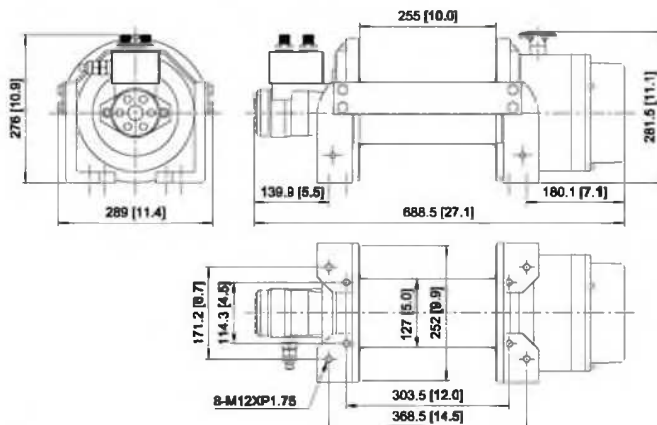

HV-12

12,000 LB Hydraulic Recovery Winch

• Meets SAE J706 revised AUG2003, CE Machinery Directive 2006/42/EC and EN 14492-1: 2006 Power Driven Winches

PN 684311 Std. drum | PN 685433 Std. drum, Clutch in left side



Note : Roller fairlead does not mount to winch

SPECIFICATIONS :

Rated line pull : 5,440 kg (12,000 lb) SAE J706 rating
5,100 kg EN 14492-1 rating

Operation pressure : 150 bar / 2,175 psi

Max oil flow : 60 l/min (15.9 g/min)

Hydraulic motor : 125 cm³ / rev (7.6 in³ / rev)

Gear train & ratio : 2-stage planetary 19.4:1

Winch construction : Aluminum die cast housings with steel drum

Clutch (freespooling) : Rotating ring gear

Brake : Spring applied drag brake together with over-center valve supplied

Rotation of winch : Wire rope shall be under-wound orientation only

Drum barrel diameter : 114.3 mm (4.5")

Drum flange diameter : 252 mm (9.9")

Drum between flanges : 255 mm (10.0")

Mounting bolt pattern :

303.5 x 114.3 mm (12.0" x 4.5") ; 368.5 x 171.2 mm (14.5" x 6.7")

Wire rope recommended :

12 mm x 39 m (1/2" x 128'), 1,960 N/mm² (EIPS) grade with a minimum breaking strength of 100.5 KN (22,552 lbf) required for SAE J706 and EN 14492-1 ratings

Winch weight : 71 kg / 156.5 lb

Gross weight : 87 kg / 191.8 lb

Box dimension, (L x D x H) : 735 x 430 x 335 mm (29" x 16.9" x 13.2")

PERFORMANCE DATA :

Layer of Wire Rope	Line Pull and Rope Capacity		Line Speed
	Pull by Layer, kg / lb	Total Rope on the Drum, m / ft	at 60 l/min (15.9 g/min), mpm / fpm
1 st	5,440 / 12,000	8.2 / 26.9	10.0 / 33.0
2 nd	4,570 / 10,075	18.0 / 59.1	11.6 / 38.1
3 rd	3,939 / 8,684	29.3 / 96.1	13.5 / 44.3
4 th	3,462 / 7,632	39.0 / 128.0	15.4 / 50.5

DIMENSION mm/in :

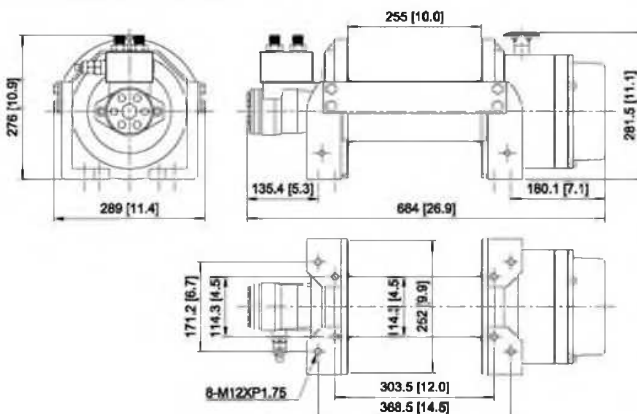

10,000 LB Hydraulic Recovery Winch

- Meets SAE J706 revised AUG2003, CE Machinery Directive 2006/42/EC and EN 14492-1: 2006 Power Driven Winches
PN 682546 Std. drum | PN 683129 Std. drum, Clutch in left side



Note : Roller fairlead does not mount to winch

SPECIFICATIONS :

- Rated line pull : 4,535 kg (10,000 lb) SAE J706 rating
4,300 kg EN 14492-1 rating
- Operation pressure : 150 bar / 2,175 psi
- Max oil flow : 60 l/min (15.9 g/min)
- Hydraulic motor : 97.3 cm³ / rev (5.9 in³ / rev)
- Gear train & ratio : 2-stage planetary 16:1
- Winch construction : Aluminum die cast housings with steel drum
- Clutch (freespooling) : Rotating ring gear
- Brake : Spring applied drag brake together with over-center valve supplied
- Rotation of winch : Wire rope shall be under-wound orientation only
- Drum barrel diameter : 102 mm (4.0")
- Drum flange diameter : 201.5 mm (7.9")
- Drum between flanges : 253 mm (10")
- Mounting bolt pattern :
291.6 x 171.2 mm (11.5" x 6.7") ; 374.2 x 114.3 mm (14.7" x 4.5")
- Wire rope recommended :
11 mm x 27 m (7/16" x 89'), 1,960 N/mm² (EIPS) grade with a minimum breaking strength of 84.4 KN (18,939 lbf) required for SAE J706 and EN 14492-1 ratings
- Winch weight : 37 kg / 81.4 lb
- Gross weight : 46.6 kg / 102.5 lb
- Box dimension, (L x D x H) : 680 x 380 x 300 mm (26.8" x 15" x 11.8")

PERFORMANCE DATA :

Layer of Wire Rope	Line Pull and Rope Capacity		Line Speed
	Pull by Layer, kg / lb	Total Rope on the Drum, m / ft	at 60 l/min (15.9 g/min), mpm / fpm
1 st	4,535 / 10,000	8.0 / 26.2	14.0 / 46.0
2 nd	3,796 / 8,369	17.5 / 57.4	16.3 / 53.5
3 rd	3,264 / 7,196	27.0 / 89.0	19.0 / 62.3

DIMENSION mm/in :

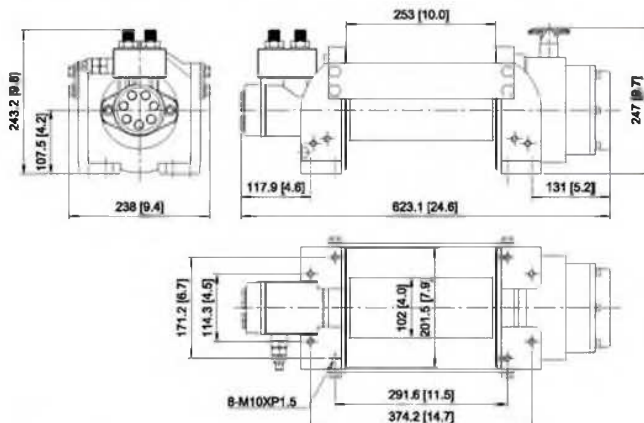

HV-8

8,000 LB Hydraulic Recovery Winch

- Meets SAE J706 revised AUG2003, CE Machinery Directive 2006/42/EC and EN 14492-1: 2006 Power Driven Winches
PN 680816 (Std. drum) | **PN 681091** (Long drum)
PN 681123 (Std. drum, Clutch in left side) | **PN 681347** (Long drum, Clutch in left side)



Note : Roller fairlead does not mount to winch

SPECIFICATIONS :

- Rated line pull :** 3,630 kg (8,000 lb) SAE J706 rating
3,560 kg EN 14492-1 rating
- Operation pressure :** 150 bar / 2,175 psi
- Max oil flow :** 60 l/min (15.9 g/min)
- Hydraulic motor :** 77.8 cm³ / rev (4.7 in³ / rev)
- Gear train & ratio :** 2-stage planetary 16:1
- Winch construction :** Aluminum die cast housings with steel drum
- Clutch (freespooling) :** Rotating ring gear
- Brake :** Spring applied drag brake together with over-center valve supplied
- Rotation of winch :** Wire rope shall be under-wound orientation only
- Drum barrel diameter :** 90 mm (3.5")
- Drum flange diameter :** 201.5 mm (7.9")
- Drum between flanges :** 190 mm (7.5") - Std. drum ; 253 mm(10") - Long drum
- Mounting bolt pattern :**
Std. drum - 228.6 x 171.2 mm (9.0" x 6.7") ; 311.2 x 114.3 mm (12.3" x 4.5")
Long drum - 291.6 x 171.2 mm (11.5" x 6.7") ; 374.2 x 114.3 mm (14.7" x 4.5")
- Wire rope recommended :**
10 mm x 30.5 m (3/8" x 100') for Std. drum and 40 m (131') for long drum, 1,960 N/mm² (EIPS) grade with a minimum breaking strength of 69.8 KN (15,663 lbf) required for SAE J706 and EN 14492-1 ratings
- Winch weight :** 35.5 kg / 78.1 lb (Std. drum) ; 37.5 kg / 82.7 lb (Long drum)
- Gross weight :** 43.3 kg / 95.3 lb (Std. drum) ; 45.3 kg / 99.9 lb (Long drum)
- Box dimension, (L x D x H) :**
615 x 380 x 300 mm (24.2" x 15" x 11.8") -Std. drum
680 x 380 x 300 mm (26.8" x 15" x 11.8") - Long drum

PERFORMANCE DATA :

Layer of Wire Rope	Line Pull and Rope Capacity		Line Speed	
	Pull by Layer, kg / lb	Total Rope on the Drum, m / ft	Std. drum	Long drum
1 st	3,630 / 8,000	5.8 / 19.0	7.8 / 25.6	15.0 / 49.0
2 nd	3,025 / 6,669	12.8 / 42.0	17.1 / 56.1	18.2 / 59.7
3 rd	2,593 / 5,717	20.9 / 68.6	28.0 / 91.9	21.2 / 69.6
4 th	2,269 / 5,002	30.5 / 100	40 / 131	24.2 / 79.4

DIMENSION mm/in :

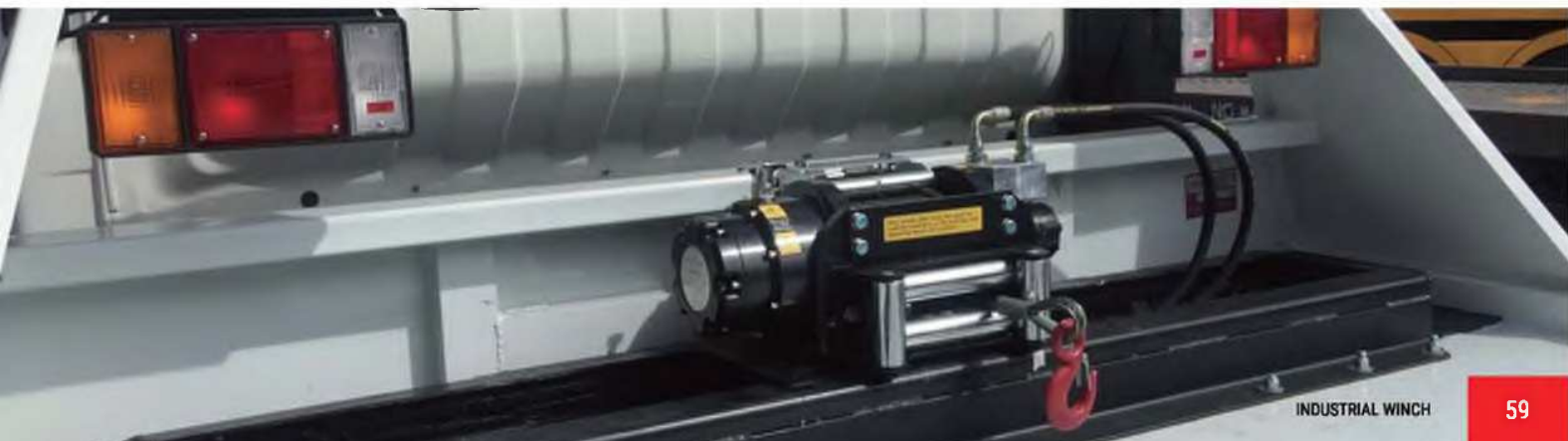
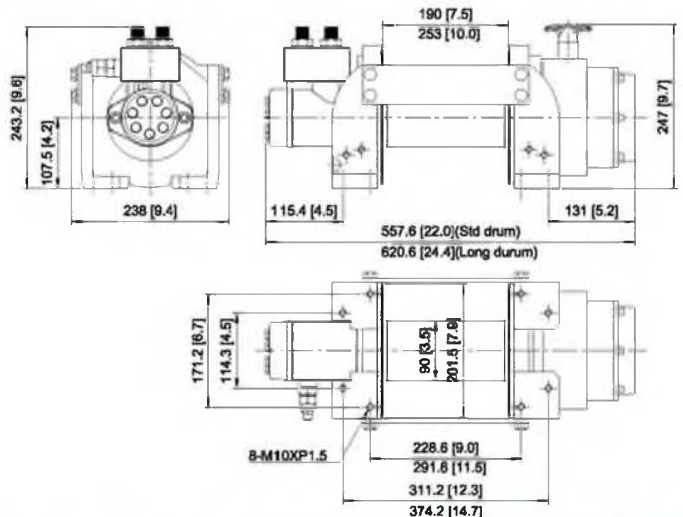

HYDRAULIC WORM GEAR WINCH



- Powered by an onboard hydraulic pump or PTO
- Fast and variable recovery speeds for high working rate
- High efficient and constant-operating torque motor
- Irreversible single stage worm gear provides instant braking and slip free operation
- An ergonomic T-handle for rapid wire rope payout
- Heavy duty roller fairlead with grease zerks fittings
- EN 14492-1 supported: 10:1 D/d ratio, 2:1 wire rope strength and 1.5d freeboard for severe duty car and commercial recovery
- Standard Compliance : SAE J706, CE Machinery Directive 2006/42/EC, and EN 14492-1:2006 Power Driven Winches.

Compliant with EN 14492-1 requirements for recovery winch:

- * The working coefficient for the first rope layer on the drum shall be at least 2.
- * The D/d ratio to the center of the rope shall be at least 10 for the drum.
- * Drum freeboard shall be at least 1.5 x rope diameter.

Hydraulic System

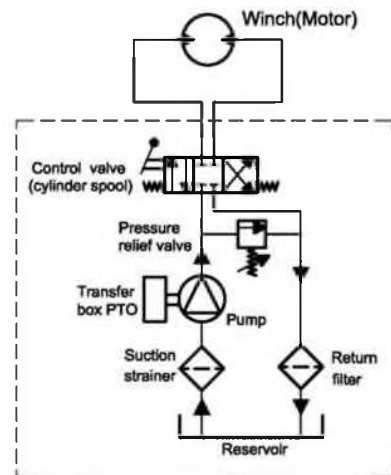

Customer supplied



Yak 7

7,000 LB Hydraulic Worm Gear Winch

· Meets SAE J706 revised AUG2003, CE Machinery Directive 2006/42/EC and EN 14492-1:2006 Power Driven Winches

PN 681260 Std. dum | PN 681266 Long dum



Note : Roller fairlead does not mount to winch

SPECIFICATIONS :

Rated line pull : 3,175 kg (7,000 lb) SAE J706 rating
3,200 kg EN 14492-rating

Operation pressure : 120 bar / 1,740 psi

Max oil flow : 40 l/min (10.6 g/min)

Hydraulic motor : 48.6 cm³ / rev (3.0 in³ / rev)

Gear train & ratio : 1-stage worm gear 50:1

Winch construction : Aluminum die cast housings with steel drum

Clutch (Freespooling) : Worm gear disengaged

Brake : Irreversible worm gear

Rotation of winch : Wire rope shall be under-wound orientation only

Drum barrel diameter : 90 mm (3.5")

Drum flange diameter : 168 mm (6.6")

Distance between flanges : 160 mm (6.3") - Std. drum / 240 mm (9.5") - Long drum

Mounting bolt pattern : 130 x 211 mm (5.1" x 8.3") - Std. drum

130 x 291 mm (5.1" x 11.5") - Long drum

Wire rope recommended :

10 mm x 10.7 m for Std. drum and 16.2 m for Long drum, 1,960N/mm² grade with a minimum breaking strength of 69.8 kN required for EN 14492-1 rating

3/8" x 57.4' for Std. drum and 87.3' for Long drum, EIPS grade with a minimum breaking strength of 15,663 lbf required for SAE J706 rating

Winch weight : 29 kg / 63.9 lb (Std. drum) ; 33 kg / 72.8 lb (Long drum)

Gross weight : 33 kg / 72.8 lb (Std. drum) ; 37 kg / 81.6 lb (Long drum)

Box dimension, (L x D x H) : 431 x 386 x 256 mm (17" x 15.2" x 10.1") - Std. drum

511 x 386 x 256 mm (20.1" x 15.2" x 10.1") - Long drum

PERFORMANCE DATA :

Layer of Wire Rope	Line Pull and Rope Capacity		Line Speed	
	Pull by Layer, kg / lb	Total Rope on the Drum, m / ft Std. drum Long drum	at 40 l/min (10.6 g/min), mpm / fpm	
1 st	3,175 / 7,000	4.9 / 16.1 7.4 / 24.3	5.2 / 17.1	
2 nd	2,646 / 5,833	10.7 / 35.1 16.2 / 53.1	6.2 / 20.3	
3 rd	2,268 / 5,000	17.5 / 57.4 26.6 / 87.3	7.2 / 23.6	

DIMENSION mm/in :

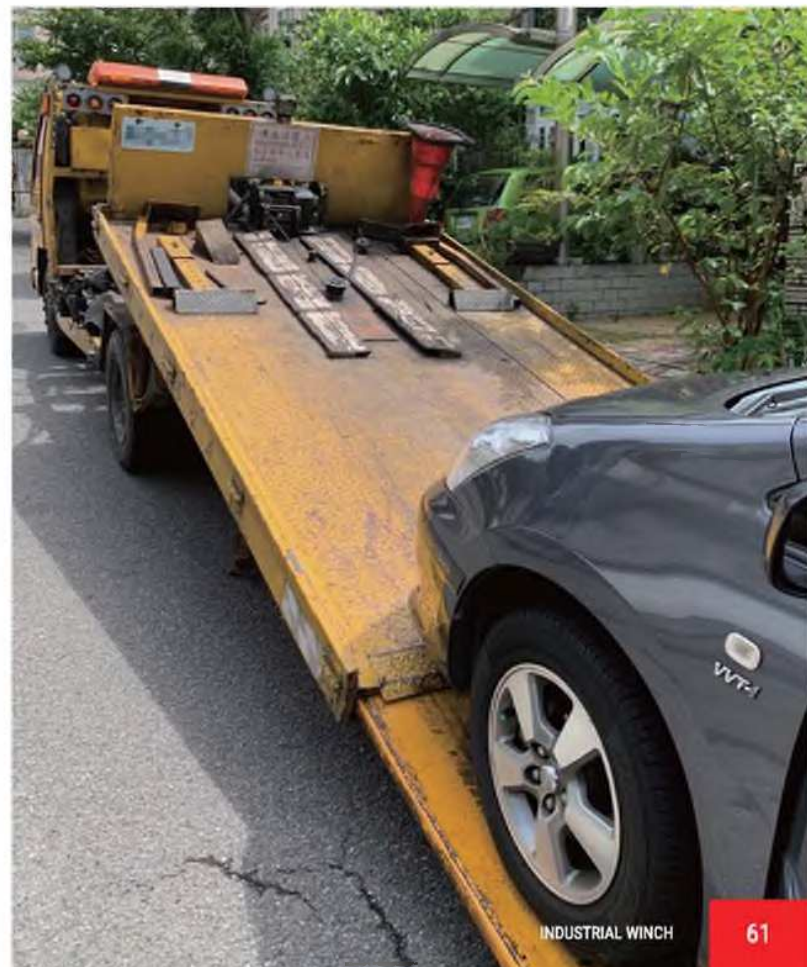
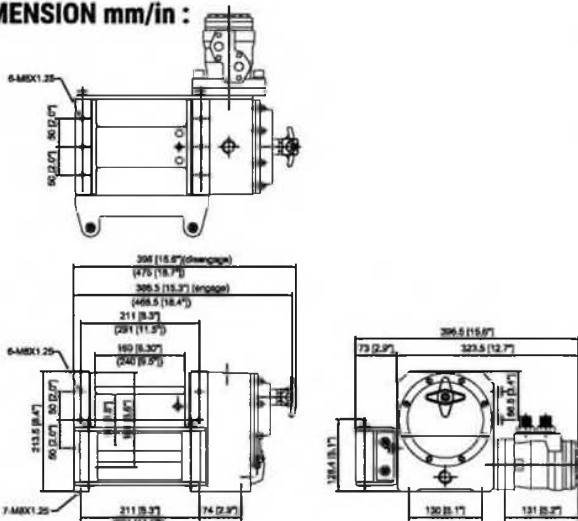

Electric Recovery Winch

COMEUP, as an international brand of winch manufacturer, is aiming to provide a superior product that is inherently safe to operate in all conditions by all users. COMEUP further assures that its industrial winches comply with all European Standards and Directives including but not limited to EN 14492-1, the Machinery Safety regulations and all current Health and Safety regulations. COMEUP Rhino & Rhino Pro Series winches are designed to comply the above regulation requirements that ensures maximum performance in the toughest environment and is ideal for commercial, industrial and severe duty application.

- ▶ Rhino & Rhino Pro Series 8,000 ~ 15,000 lb
- ▶ Wolf Series 8,500 ~ 12,000 lb

Rhino & Rhino Pro Series

8,000 - 12,000 - 15,000 lb pulling capacity



- ▶ Reliable electric winch for commercial, industrial and severe duty applications.
- ▶ Hardened steel, 3-stage planetary gear train for efficient and reliable operation.
- ▶ Waterproof remote control with thermometric LED indicator alerts when the motor is over-heated.
- ▶ Patented over-loading current protector can be programmed by the winch specification and pulling requirements which limits the winch's maximum pulling power. (Rhino Pro Series)
- ▶ LED Indicator displays detailed winch status while operating. (Rhino Pro Series)
- ▶ Low voltage detecting function reminds operator vehicle battery status. (Rhino Pro Series)
- ▶ U.S. Germany, U.K., France, etc patented mechanical cone brake holds the full load without slipping.
- ▶ Easy to turn the T-handle for rapid wire rope payout.
- ▶ Submersible sealed contactor handles high amps and allows higher duty cycle.
- ▶ Meets CE Machinery Directive 2006/42/EC, CE Electromagnetic Compatibility 2014/30/EU, and EN 14492-1 : 2006 Power Driven Winches.

- ▶ Compliant with EN 14492-1 requirements for recovery winch :
 - The working coefficient for the first rope layer on the drum shall be at least 2.
 - The D/d ratio to the center of the rope shall be at least 10 for the drum.
 - Drum freeboard shall be at least 1.5 x rope diameter.
- ▶ Intelligent Control Box (ICB)
 - The ICB designed to allow adjustment of a winch's maximum pulling power.
 - Patented over-loading current protector can be programmed by the winch specification and pulling requirements which limits the winch's maximum pulling power.
 - Optional digits regulator panel for setting up overload current and also shows instant battery voltage value while operating winch.
 - LED Indicator displays detailed winch status while operating.
 - Low voltage detecting function reminds operator vehicle battery status.
 - Durable aluminum alloy die cast housings.
 - IP68 rated waterproof.
 - Applicable for other brands of winches.

- ▶ **Current Regulator (sold separately) PN 883558**
 - The Current Regulator is a device to adjust CLP (Current Limit Point) in ICB Control Box.
 - Once the Current Regulator is connected to the ICB control box, the technician can adjust the CLP in order to limit the winch's maximum pulling power.
 - Only trained dealers and representatives are allowed to use this device to adjust the CLP.

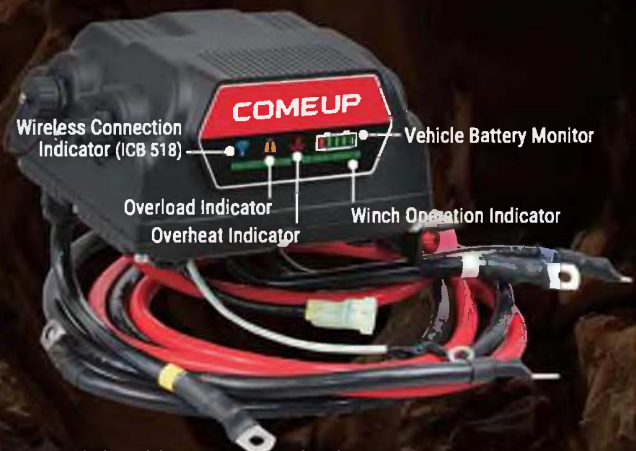

- ▶ ICB - Limited Three (3) Years Warranty for Electric Components

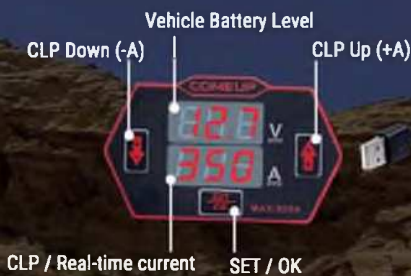

Rhino 15/15 Pro

15,000 LB Electric Recovery Winch

- Meets CE Machinery Directive 2006/42/EC, CE Electromagnetic Compatibility 2014/30/EU, and EN 14492-1 : 2006 Power Driven Winches
- Rhino 15 PN 851540 24V | Rhino 15 Pro PN 855126 24V



SPECIFICATIONS :

- Rated line pull : 6,804 kg (15,000 lb) single line, EN 14492-1 rating
- Motor : 5,250 w / 7.0 hp, 24V series wound
- Gear train & ratio : 3-stage planetary 315:1
- Clutch (freespooling) : Rotating ring gear
- Brake (outside the drum) : Automatic, full load CBS (Cone Brake Structure)
- Winch construction : Aluminum die cast housings with steel drum
- Drum size : 133 x 195.5 mm (5.2" x 7.7")
- Rotation of winch : Wire rope shall be under-wound orientation only
- Control : Waterproof remote with thermometric indicator LED and 5 m (17') cord
- Mounting bolt pattern : 254 x 114.3 mm (10" x 4.5") ; 254 x 165.1 mm (10" x 6.5")
- Wire rope recommended : 14 mm x 22 m, 1,960/mm² grade with a minimum breaking strength of 137 kN required for EN 14492-1 rating
- Winch weight : 59 kg / 130 lb
- Gross weight : Rhino 15 : 71 kg / 156.5 lb
Rhino 15 Pro : 72 kg / 159 lb
- Box dimension, (L x D x H) : Rhino 15 : 693 x 354 x 473 mm (27.3" x 13.9" x 18.6")
Rhino 15 Pro : 693 x 354 x 508 mm (27.3" x 13.9" x 20")

PERFORMANCE DATA :

Line Pull and Rope Capacity

Layer of Rope	Pull by Layer, kg / lb	Line Speed, mpm / fpm	Total Rope on the Drum, m / ft
1 st	6,804 / 15,000	1.9 / 6.2	6.2 / 20.3
2 nd	5,715 / 12,599	2.3 / 7.5	13.6 / 44.6
3 rd	4,927 / 10,862	2.6 / 8.5	22 / 72

Line Speed and Amp. Draw (1st layer of rope on the drum)

Line Pull kg / lb	Line Speed, mpm / fpm	Amp. Draw, A 24V
No Load	12.6 / 41.3	35
1,814 / 4,000	5.1 / 16.7	80
3,630 / 8,000	4.1 / 13.5	160
4,536 / 10,000	3.1 / 10.2	200
5,443 / 12,000	2.5 / 8.2	250
6,804 / 15,000	1.9 / 6.2	300

DIMENSION mm/in : (Rhino 15 Pro)

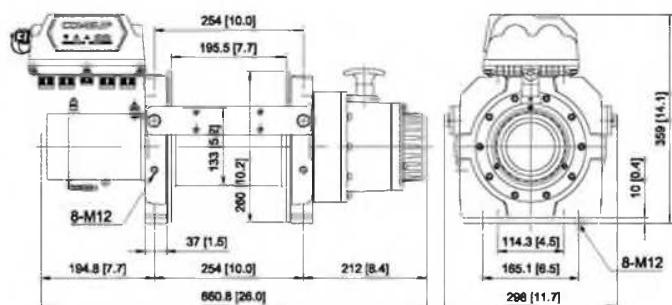

(Rhino 15)

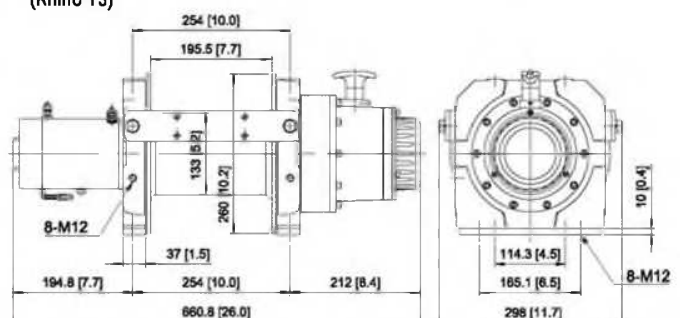

COMEUP WINCH

Rhino 12 /12 Pro

12,000 LB Electric Recovery Winch

• Meets SAE J706, CE Machinery Directive 2006/42/EC, CE Electromagnetic Compatibility 2014/30/EU, and EN 14492-1:2006 Power Driven Winches.

Rhino 12 PN 851212 12V | PN 851224 24V
Rhino 12 Pro PN 851105 12V | PN 851324 24V



Note : Roller fairlead does not mount to winch



SPECIFICATIONS :

Rated line pull : 5,440 kg (12,000 lb) single line, SAE J706 rating
5,100 kg single line, EN 14492-1 rating

Motor : 4,180 w / 5.6 hp, 12V series wound
2,690 w / 3.6 hp, 24V series wound

Gear train & ratio : 3-stage planetary 315:1

Clutch (freespooling) : Rotating ring gear

Brake (outside the drum) : Automatic, full load CBS (Cone Brake Structure)

Winch construction : Aluminum die cast housings with steel drum

Drum size : 114 x 195.5 mm (4.5" x 7.7")

Rotation of winch : Wire rope shall be under-wound orientation only

Control : Waterproof remote with thermometric indicator LED and 5 m (17') cord

Mounting bolt pattern : 254 x 114.3 mm (10" x 4.5"); 254 x 165.1 mm (10" x 6.5")

Wire rope recommended :

* 12 mm x 21.4 m, 1,960N/mm² grade with a minimum breaking strength of 100.5 KN required for EN 14492-1 rating

* 1/2" x 100', EIPS grade with a minimum breaking strength of 22,552 lbf required for SAE J706 rating

Winch weight : 47 kg / 104 lb

Gross weight : Rhino 12 : 61 kg / 134 lb

Rhino 12 Pro : 62 kg / 137 lb

Box dimension, (L x D x H) : Rhino 12 : 693 x 313 x 473 mm (27.3" x 12.3" x 18.6")

Rhino 12 Pro : 693 x 313 x 508 mm (27.3" x 12.3" x 20")

PERFORMANCE DATA :

Line Pull and Rope Capacity

Layer of Rope	Pull by Layer, kg / lb	Line Speed, mpm / fpm	Total Rope on the Drum, m / ft
1 st	5,440 / 12,000	1.3 / 4.3	5.9 / 19.4
2 nd	4,534 / 9,996	1.5 / 12.1	13 / 42.7
3 rd	3,885 / 8,565	1.8 / 14.3	21.4 / 70.2
4 th	3,399 / 7,494	2.0 / 16.4	30.5 / 100

Line Speed and Amp. Draw (1st layer of rope on the drum)

Line Pull kg / lb	Line Speed, mpm / fpm	Amp. Draw, A	
		12V	24V
No Load	10 / 32.8	40	35
1,814 / 4,000	4.4 / 14.4	140	110
3,629 / 8,000	3.5 / 11.5	280	210
4,536 / 10,000	1.5 / 5.0	350	260
5,440 / 12,000	1.3 / 4.3	420	310

DIMENSION mm/in : (Rhino 12 Pro)

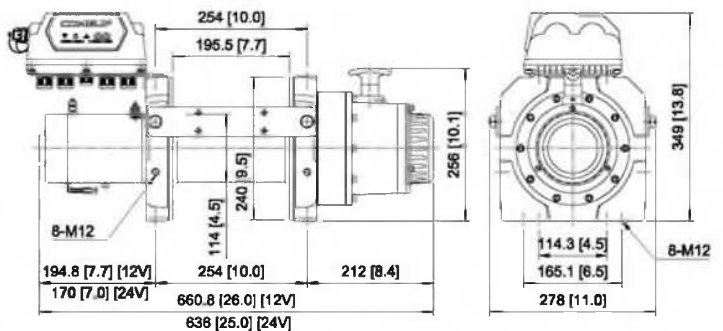

(Rhino 12)

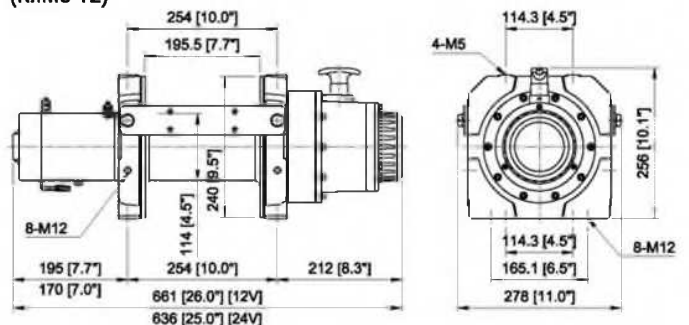

Rhino 8/8 Pro

8,000 LB Electric Recovery Winch

• Meets SAE J706, CE Machinery Directive 2006/42/EC, CE Electromagnetic Compatibility 2014/30/EU, and EN 14492-1:2006 Power Driven Winches.

Rhino 8 PN 850812 12V | PN 850824 24V

Rhino 8 Pro PN 850318 12V | PN 850326 24V



Note : Roller fairlead does not mount to winch

SPECIFICATIONS :

Rated line pull : 3,630 kg (8,000 lb) single line, SAE J706 rating
3,560 kg single line, EN 14492-1 rating

Motor : 3,430 w / 4.6 hp, 12V series wound
1,940 w / 2.6 hp, 24V series wound

Gear train & ratio : 3-stage planetary 211:1

Clutch (freespooling) : Rotating ring gear

Brake (outside the drum) : Automatic, full load CBS (Cone Brake Structure)

Winch construction : Aluminum die cast housings with steel drum

Drum size : 90 x 205 mm (3.5" x 8.1")

Rotation of winch : Wire rope shall be under-wound orientation only

Control : Waterproof remote with thermometric indicator LED and 5 m (17') cord

Mounting bolt pattern : 254 x 114 mm (10" x 4.5"); 254 x 165.1 mm (10" x 6.5")

Wire rope recommended :

* 10 mm x 22.6 m, 1,960 N/mm² with a minimum breaking strength of 69.8 kN required for EN 14492-1 rating

* 3/8" x 100', EIPS grade with a minimum breaking strength of 15,663 lbf required for SAE J706 rating

Winch weight : 31 kg / 68.3 lb

Gross weight : Rhino 8 : 47 kg / 104 lb

Rhino 8 Pro : 48 kg / 106 lb

Box dimension, (L x D x H) : 650 x 260 x 440 mm (25.6" x 10.2" x 17.3")

PERFORMANCE DATA :

Line Pull and Rope Capacity

Layer of Rope	Pull by Layer, kg / lb	Line Speed, mpm / fpm	Total Rope on the Drum, m / ft
1 st	3,630 / 8,000	0.7 / 2.3	6.3 / 20.7
2 nd	3,025 / 6,669	0.9 / 3.0	13.8 / 45.3
3 rd	2,593 / 5,717	1.0 / 3.3	22.6 / 74.1
4 th	2,269 / 5,002	1.2 / 4.0	30.5 / 100

Line Speed and Amp. Draw (1st layer of rope on the drum)

Line Pull kg / lb	Line Speed, mpm / fpm	Amp. Draw, A	
		12V	24V
No Load	9.0 / 29.5	45	30
907 / 2,000	3.0 / 10	90	60
1,814 / 4,000	1.5 / 5.0	180	120
2,722 / 6,000	1.0 / 3.3	260	180
3,630 / 8,000	0.7 / 2.3	340	230

DIMENSION mm/in : (Rhino 8 Pro)

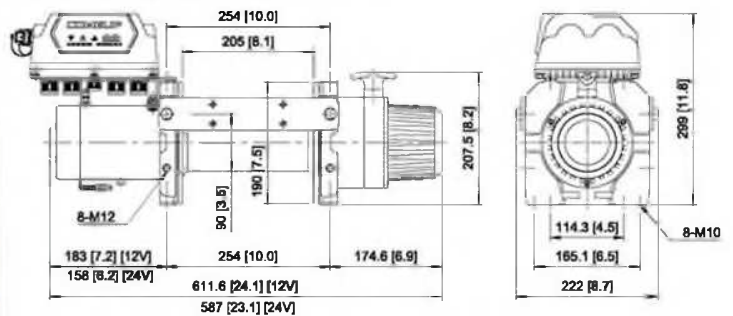

(Rhino 8)

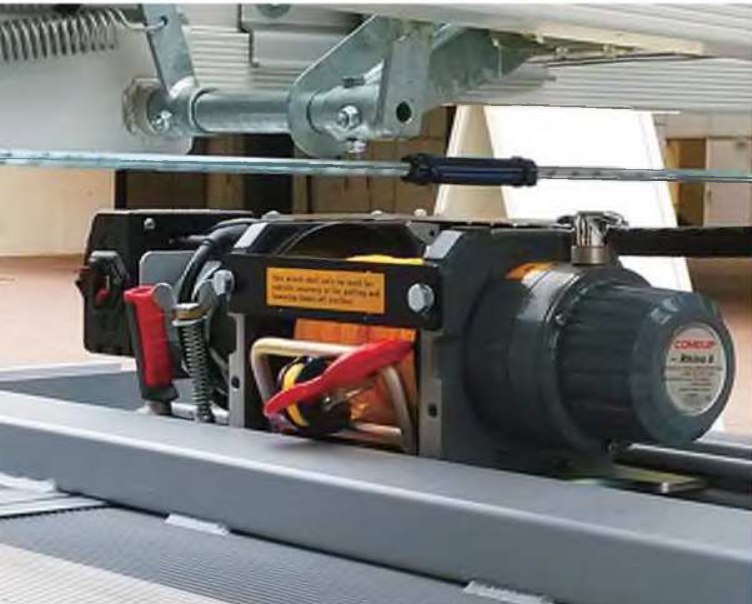
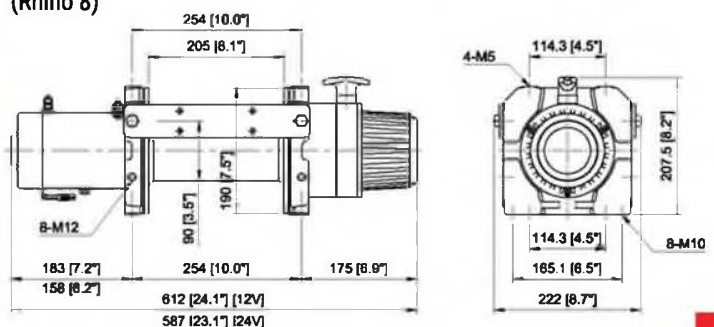

12,000/8,500 LB Electric Worm Gear Winch

· Meets SAE J706, CE Machinery Directive 2006/42/EC, and REMSA Standards

Wolf 12.0 PN 782478 12V | PN 783415 24V (with wire rope, roller fairlead, remote control, cable tensioner)

Wolf 8.5 PN 780254 12V | PN 780988 24V (with wire rope, roller fairlead, remote control, cable tensioner)



Note : Roller fairlead does not mount to winch

SPECIFICATIONS :

Rated line pull :

Wolf 12.0 : 5,443 kg (12,000 lb) single line (SAE J706 rating)

Wolf 8.5 : 3,856 kg (8,500 lb) single line (SAE J706 rating)

Motor :

Wolf 12.0/8.5 : 3,430 w / 4.6 hp, 12V series wound

Wolf 12.0 : 2,240 w / 3.0 hp, 24V series wound

Wolf 8.5 : 1,940 w / 2.6 hp, 24V series wound

Gear train & ratio :

Wolf 12.0 : 2-stage spur gears PLUS worm gear 424:1

Wolf 8.5 : 2-stage spur gears PLUS worm gear 228.9:1

Clutch (freespooling) : Mechanism lever

Brake : Irreversible worm gear brake PLUS mechanism ratchet wheel brake

Drum size : Wolf 12.0 : 89 mm x 229 mm (3.5" x 9")

Wolf 8.5 : 82 mm x 229 mm (3.2" x 9")

Control : Waterproof remote control w/5 m (17') cord

Rope : Wolf 12.0 : Galvanized aircraft A7 x 19, 9.5 mm x 30.5 m (3/8" x 100')

Wolf 8.5 : Galvanized aircraft A7 x 19, 8.0 mm x 45 m (5/16" x 150')

Mounting bolt pattern : 273 x 110 mm (10.7" x 4.3") ; 257 x 172 mm (10.1" x 6.8")

Winch weight : Wolf 12.0 : 41 kg / 90.4 lb

Wolf 8.5 : 40 kg / 88.2 lb

Gross weight : Wolf 12.0 : 65 kg / 143.3 lb

Wolf 8.5 : 63.4 kg / 139.7 lb

Box dimension, (L x D x H) : 610 x 427 x 350 mm (24" x 16.8" x 13.8")

PERFORMANCE DATA :

Line Pull and Rope Capacity

Model Name	Wolf 12.0		Wolf 8.5	
	Layer of Rope	Pull by Layer, Total Rope on the kg / lb Drum, m / ft	Pull by Layer, Total Rope on the kg / lb Drum, m / ft	Pull by Layer, Total Rope on the kg / lb Drum, m / ft
1 st	5,443 / 12,000	7.3 / 24.0	3,856 / 8,500	8.0 / 26.4
2 nd	4,563 / 10,060	16.0 / 52.6	3,279 / 7,229	17.5 / 57.4
3 rd	3,928 / 8,659	26.1 / 85.8	2,853 / 6,289	28.4 / 93.1
4 th	3,448 / 7,601	30.5 / 100	2,524 / 5,566	40.7 / 133.4
5 th	-	-	2,264 / 4,991	45.0 / 150.0

Line Speed and Amp. Draw (1st layer of rope on the drum)

Line Pull kg / lb	Line Speed, mpm / fpm				Amp. Draw, A			
	Wolf 12.0		Wolf 8.5		Wolf 12.0		Wolf 8.5	
	12V	24V	12V	24V	12V	24V	12V	24V
No Load	3.5/10.1	5.0/16.4	7.0/23.0	9.5/31.2	70	50	60	50
907 / 2,000	-	-	3.0/9.8	5.0/16.4	-	-	160	130
1,814 / 4,000	-	-	2.2/7.2	3.0/9.8	-	-	220	190
2,722 / 6,000	1.1/3.6	1.8/5.9	1.5/4.9	2.3/7.5	180	150	300	250
3,630 / 8,000	0.8/2.6	1.3/4.3	1.1/3.6	1.3/4.3	270	190	390	320
3,856 / 8,500	-	-	1.0/3.3	1.2/3.9	-	-	430	360
4,535 / 10,000	0.6/2.0	1.1/3.6	-	-	310	230	-	-
5,443 / 12,000	0.3/1.0	0.7/2.3	-	-	350	270	-	-

DIMENSION mm/in : (Wolf 12.0/8.5)

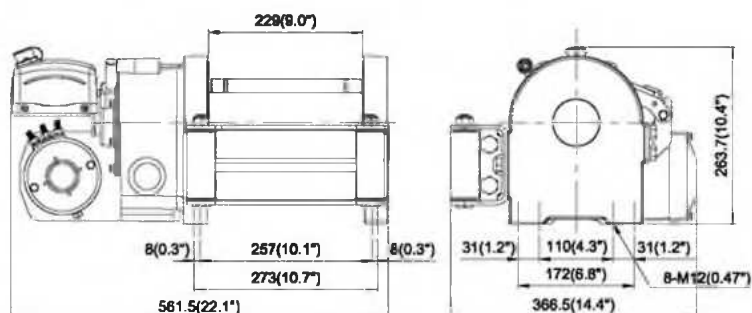

HEAVY DUTY DC HOIST

The GTD Series of heavy duty hoists are designed and built for use in the most demanding environments today's work trucks encounter. Through rigorous testing and validation processes these hoists are proven to meet global industry safety and durability standards.

Built using high efficiency, low amp draw permanent magnet motors the GTD Series hoists are extremely efficient while offering category leading safety. Our full metal 3-stage planetary gear sets offer greater lifting force and provide many years of reliable component service. COMEUP's submersible sealed contactor easily handles the high amperage demands of load lifting and allows a higher duty cycle for reliable all-day use.

All GTD Series Hoists comply with CE Machinery Directive 2006/42/EC, CE EMC Directive 2014/30/EU and ASME B30.5

- Provides an answer to the health and safety recommendations for manual lifting
- High efficiency low amp. draw and sealed permanent magnet motor
- Lightweight and compact design is ideal for easy installation
- Mechanical cone brake and permanent magnet motor dynamic braking work together for safe, controlled load handling
- Waterproof industrial remote control with 5 m lead
- Full metal 3 stage planetary gear train for greater pulling force
- Submersible sealed contactor handles high amps and allows higher duty cycle
- In compliance with standard of ASME B30.5 for $D/d \geq 18$ and rope safety factor ≥ 3.5
- Meets CE Machinery Directive 2006/42/EC, CE EMC Directive 2014/30/EU and ASME B30.5

▶ GTD Series 650 ~ 2,000 lb



GTD-2800

2,800 LB Heavy Duty Hoist

PN 753022 12V | PN 753033 24V

PN 753002 12V w/o controls and rope assembly

PN 753003 24V w/o controls and rope assembly



SPECIFICATIONS :

Rated load : 1,270 kg (2,800 lb)

Motor : 2,830 w / 3.8 hp, 12V permanent magnet
1,940 w / 2.6 hp, 24V permanent magnet

Gear train & ratio : 3-stage planetary 261:1

Brake (outside the drum) : Mechanical cone brake and permanent motor dynamic brakes together

Winch construction : Aluminum die cast housings and steel drum

Drum size : 135 x 114.6 mm (5.3" x 4.5")

Control : Remote control with 5 m (17') lead

Rope : Galvanized aircraft A7 x 19, 7.9 mm x 28 m (5/16" x 92')

Mounting bolt pattern : 114.3 x 171 mm (4.5" x 6.8") ; 165.1 x 171 mm (6.5" x 6.8")

Hoist weight (including rope & hook) : 48.1 kg / 106 lb

Gross weight : 54.8 kg / 120.8 lb

Box dimension, (L x D x H) : 620 x 360 x 260 mm (24.4" x 14.2" x 10.2")

PERFORMANCE DATA :

Line Pull and Rope Capacity

Layer of Wire Rope	Load by Layer, kg / lb	Line Speed mpm / fpm		Total Rope on the Drum, m / ft
		12V	24V	
1 st	1,270 / 2,800	4.0 / 13.1	4.4 / 14.4	6.3 / 20.7
2 nd	1,144 / 2,522	4.4 / 14.4	4.9 / 16.1	13.3 / 43.6
3 rd	1,040 / 2,292	4.8 / 15.7	5.4 / 17.7	21 / 68.6
4 th	954 / 2,103	5.3 / 17.4	5.8 / 19.0	28 / 92

Line Speed and Amp. Draw (1st layer of rope on the drum)

Line Pull kg / lb	Line Speed, mpm / fpm		Amp. Draw, A		Percentage Duty Cycle Min / 10 min
	12V	24V	12V	24V	
No Load	5.8 / 19	6.0 / 19.7	30	22	Cont.
227 / 500	5.5 / 18	5.7 / 18.7	45	30	7.0
454 / 1,000	5.1 / 16.7	5.5 / 18.0	70	45	4.5
680 / 1,500	4.6 / 15.1	5.3 / 17.4	95	60	3.0
907 / 2,000	4.3 / 14.1	4.6 / 15.1	135	80	2.5
1,270 / 2,800	4.0 / 13.1	4.4 / 14.4	160	100	2.0

DIMENSION mm/in :

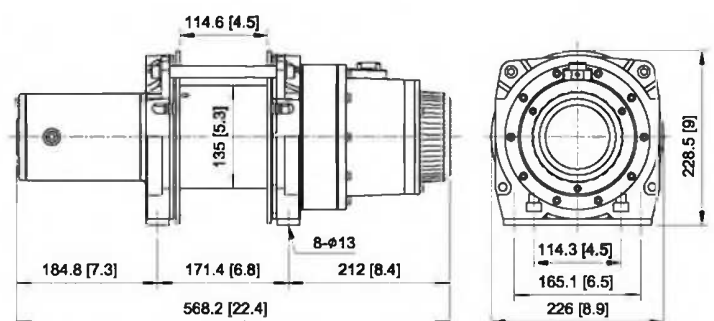

GTD-2200

2,200 LB Heavy Duty Hoist

PN 752103 12V | PN 752104 24V

PN 752003 12V w/o controls and rope assembly

PN 752004 24V w/o controls and rope assembly



SPECIFICATIONS :

Rated load : 998 kg (2,200 lb)

907 kg (2,000 lb) ASME B30.5 rating

Motor : 2,830 w / 3.8 hp, 12V permanent magnet

1,940 w / 2.6 hp, 24V permanent magnet

Gear train & ratio : 3-stage planetary 211:1

Brake (outside the drum) : Mechanical cone brake and permanent motor dynamic brakes together

Winch construction : Aluminum die cast housings and steel drum

Drum size : 108 x 105 mm (4.3" x 4.1")

Control : Remote control with 5 m (17') lead

Rope : Galvanized aircraft A7 x 19, 6.3 mm x 30.5 m (1/4" x 100')

Mounting bolt pattern : 114.3 x 152 mm (4.5" x 6") ; 165.1 x 152 mm (6.5" x 6")

Hoist weight (including rope) : 33.9 kg / 74.7 lb

Gross weight : 39.5 kg / 87.1 lb

Box dimension, (L x D x H) : 518 x 341 x 240 mm (20.4" x 13.4" x 9.4")

PERFORMANCE DATA :

Line Pull and Rope Capacity

Layer of Wire Rope	Load by Layer, kg / lb	Line Speed, mpm / fpm		Total Rope on the Drum, m / ft
		12V	24V	
1 st	998 / 2,200	4.2 / 13.8	5.0 / 16.4	5.6 / 18.4
2 nd	898 / 1,980	4.6 / 15.1	5.5 / 18.0	11.8 / 38.7
3 rd	816 / 1,799	5.1 / 16.7	6.1 / 20.0	18.7 / 61.4
4 th	747 / 1,647	5.6 / 18.4	6.6 / 21.6	26.2 / 86
5 th	689 / 1,519	6.0 / 19.7	7.2 / 23.6	30 / 100

Line Speed and Amp. Draw (1st layer of rope on the drum)

Line Pull kg / lb	Line Speed, mpm / fpm		Amp. Draw, A		Percentage Duty Cycle Min / 10 min
	12V	24V	12V	24V	
No Load	5.3 / 17.4	5.8 / 19.0	25	18	Cont.
181 / 400	5.2 / 17.1	5.7 / 18.7	50	25	8.0
362 / 800	5.1 / 16.7	5.6 / 18.4	75	35	6.0
544 / 1,200	4.8 / 15.7	5.5 / 18	95	55	4.0
771 / 1,700	4.6 / 15.1	5.3 / 17.4	115	70	3.0
998 / 2,200	4.2 / 13.8	5.0 / 16.4	135	90	2.0

DIMENSION mm/in

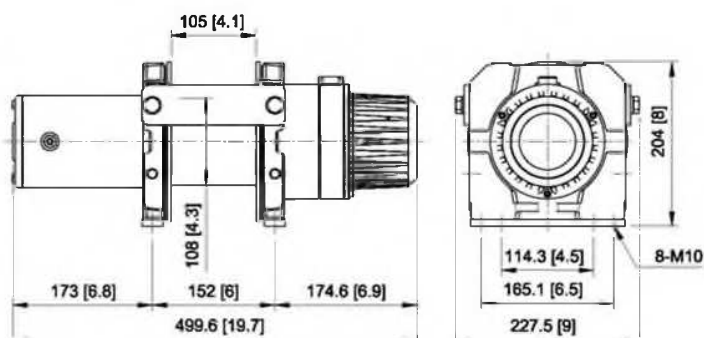

GTD-1200

1,200 LB Heavy Duty Hoist

PN 751321 12V | PN 751375 24V
 PN 751220 12V w/o controls and rope assembly
 PN 751265 24V w/o controls and rope assembly



SPECIFICATIONS :

Rated load : 544 kg (1,200 lb)
Motor : 900 w / 1.2 hp, 12/24V permanent magnet
Gear train & ratio : 3-stage planetary 216:1
Brake (outside the drum) :
 Mechanical cone brake and permanent motor dynamic brakes together
Winch construction : Aluminum die cast housing with cast iron drum
Drum size : 89 x 73 mm (3.5" x 2.9")
Control : Remote control with 5 m (17') lead
Rope : Galvanized aircraft A7 x 19, 4.8 mm x 18.3 m (3/16" x 60")
Mounting bolt pattern : 114 x 101.6 mm (4.5" x 4")
Hoist weight (including rope) : 15.3 kg / 33.7 lb
Gross weight : 20.2 kg / 44.5 lb
Box dimension, (L x D x H) : 504 x 214 x 363 mm (19.8" x 8.4" x 14.3")

PERFORMANCE DATA :

Line Pull and Rope Capacity

Layer of Wire Rope	Load by Layer, kg / lb	Line Speed, mpm / fpm	Total Rope on the Drum, m / ft
1 st	544 / 1,200	5.5 / 18	4.2 / 13.8
2 nd	494 / 1,089	6.1 / 19.9	8.8 / 28.9
3 rd	452 / 996	6.6 / 21.7	13.8 / 45.3
4 th	416 / 917	7.2 / 23.6	18.3 / 60

Line Speed and Amp. Draw (1st layer of rope on the drum)

Line Pull kg / lb	Line Speed, mpm / fpm		Amp. Draw, A		Percentage Duty Cycle Min / 10 min
	12V	24V	12V	24V	
No Load	7.4 / 24.3	5.9 / 19.4	30	15	2.5
136 / 300	6.9 / 22.6	5.7 / 18.7	55	19	2.3
272 / 600	6.4 / 21.0	5.5 / 18.0	75	25	2.0
408 / 900	5.9 / 19.4	5.2 / 17.1	95	36	1.8
544 / 1,200	5.5 / 18.0	5.0 / 16.4	130	50	1.5

DIMENSION mm/in :

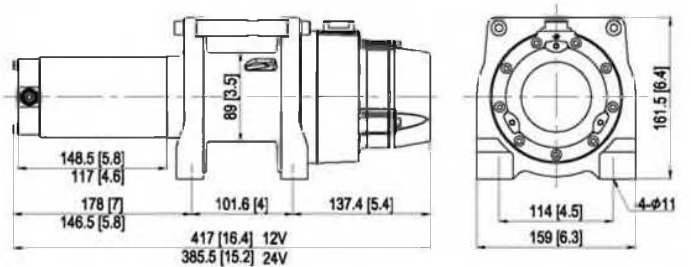

GTD-800/650

800/650 LB Heavy Duty Hoist



GTD-800
PN 750925 12V | PN 750955 24V
PN 750888 12V w/o controls and rope assembly
PN 750898 24V w/o controls and rope assembly

SPECIFICATIONS :

Rated load : 362 kg (800 lb)
Motor : 800 w / 1.0 hp, 12/24V permanent magnet
Gear train & ratio : 3-stage planetary 191:1
Brake : Mechanical spring applied and permanent motor dynamic brakes together
Winch construction : Aluminum die cast housings and drum
Drum size : 68 x 119 mm (2.7" x 4.7")
Control : Remote control with 5 m (17') lead
Rope : Galvanized aircraft A7 x 19, 4.0 mm x 18.3 m (5/32" x 60')
Mounting bolt pattern : 168 x 76 mm (6.6" x 3")
Hoist weight (including rope) : 8.3 kg / 18.3 lb
Gross weight : 12.2 kg / 26.9 lb
Box dimension, (L x D x H) : 430 x 170 x 300 mm (16.9" x 6.7" x 11.8")

PERFORMANCE DATA :

Line Pull and Rope Capacity

Layer of Wire Rope	Load by Layer, kg / lb	Line Speed, mpm / fpm	Total Rope on the Drum, m / ft
1 st	362 / 800	3.2 / 10.5	6.6 / 21.7
2 nd	327 / 721	3.6 / 11.8	14.0 / 45.9
3 rd	297 / 655	3.9 / 12.8	18.3 / 60

Line Speed and Amp. Draw (1st layer of rope on the drum)

Line Pull kg / lb	Line Speed, mpm / fpm		Amp. Draw, A		Percentage Duty Cycle Min / 10 min
	12V	24V	12V	24V	
No Load	3.6 / 11.8	4.2 / 13.8	20	15	3.0
181 / 400	3.4 / 11.2	4.1 / 13.5	40	25	2.0
362 / 800	3.2 / 10.5	4.0 / 13.1	55	35	1.5

DIMENSION mm/in :

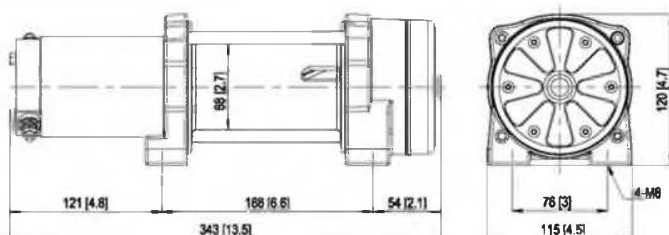

GTD-650
PN 750265 12V | PN 750280 24V
PN 750160 12V w/o controls and rope assembly
PN 750188 24V w/o controls and rope assembly

SPECIFICATIONS :

Rated load : 295 kg (650 lb)
Motor : 800 w / 1.0 hp, 12/24V permanent magnet
Gear train & ratio : 3-stage planetary 138.5:1
Brake : Mechanical spring applied and permanent motor dynamic brakes together
Winch construction : Aluminum die cast housings and drum
Drum size : 61.2 x 75 mm (2.4" x 3.0")
Control : Remote control with 5 m (17') lead
Rope : Galvanized aircraft A7 x 19, 3.6 mm x 18.3 m (9/64" x 60')
Mounting bolt pattern : 124 x 76 mm (4.9" x 3")
Hoist weight (including rope) : 7.7 kg / 17 lb
Gross weight : 11.6 kg / 25.6 lb
Box dimension, (L x D x H) : 390 x 170 x 300 mm (15.4" x 6.7" x 11.8")

PERFORMANCE DATA :

Line Pull and Rope Capacity

Layer of Wire Rope	Load by Layer, kg / lb	Line Speed, mpm / fpm	Total Rope on the Drum, m / ft
1 st	295 / 650	4.0 / 13.1	4.1 / 13.5
2 nd	266 / 586	4.5 / 14.8	8.7 / 28.5
3 rd	241 / 531	4.9 / 16	13.8 / 45.3
4 th	221 / 487	5.4 / 17.7	18.3 / 60

Line Speed and Amp. Draw (1st layer of rope on the drum)

Line Pull kg / lb	Line Speed, mpm / fpm		Amp. Draw, A		Percentage Duty Cycle Min / 10 min
	12V	24V	12V	24V	
No Load	4.3 / 14.1	5.0 / 16.4	25	15	3.0
147 / 320	4.2 / 13.8	4.8 / 15.7	45	22	2.0
295 / 650	4.0 / 13.1	4.6 / 15.1	55	30	1.5

DIMENSION mm/in :

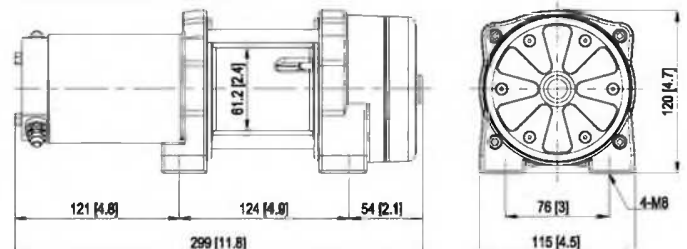

Wireless Remote Control

2.4 GHz within 27 m (90'), complete set including wireless transmitter, wireless receiver, switch cord with plug, battery and handle strap

PN 883870 RF-24DP-A w/3 ping plug for GTD-650/800/1200/2200/2800, Wolf 8.5/12.0

PN 883872 RF-24DP-C w/6 pin plug for Rhino 8/12



Remote Control

PN 880025 for GTD-650/800/1200/2200/2800, Wolf 8.5 /12.0

PN 880126 for Rhino 8/12/15 (comes with protective thermal sensor LED)

PN 883509 for Rhino 8 Pro/12 Pro/15 Pro (comes with protective thermal sensor LED)



Sealed Contactor

PN 881355 (12V) / **PN 881356** (24V)

400 A, for Rhino 8/8 Pro/12/12 Pro/15/15 Pro, Wolf 8.5/12.0

PN 882083 (12V) / **PN 882084** (24V) 250A contactor w/lead for GTD-650/800/1200/2200/2800



Control Box

PN 881581 (12V) / **PN 881582** (24V) for Rhino 8, w/built-in over-load protector

PN 881645 (12V) / **PN 881646** (24V) for Rhino 12/15, w/built-in over-load protector

PN 883406 (12V) / **PN 883521** (24V) ICB for Rhino 8 Pro/12 Pro/15 Pro

PN 882313 (12V) / **PN 882314** (24V) for GTD-650/800/1200

PN 882360 (12V) / **PN 882361** (24V) for GTD-2200/2800

PN 880340 (12V) / **PN 880341** (24V) for Wolf 8.5/12.0



Roller Fairlead

PN 880160 179 mm throat for HV-8 Std. drum, Bison 20 Std. drum / 30 Std. drum

PN 880180 245 mm throat for HV-8 Long drum, HV-10/12/15

PN 883400 245 mm throat, SUS (steel special use stainless), for HV-8 Long drum, HV-10/12/15

PN 882481 179 mm throat for Rhino 8/8 Pro/12/12 Pro/15/15 Pro

PN 881479 149 mm throat for Yak 7 Std. drum

PN 881480 229 mm throat for Yak 7 Long drum

PN 882238 330 mm throat for Bison 20 Long drum / 30 Long drum

PN 882797 330 mm throat for Bison 50

PN 880023 210 mm throat for Wolf 8.5/12.0



Snatch Block

PN 881079 Max. load 10,000 kg / 22,000 lb

PN 881082 Max. load 13,610 kg / 30,000 lb

PN 883866 Max. load 22,680 kg / 50,000 lb

PN 883621 Max. load 31,752 kg / 70,000 lb



Wire Rope with Hook

PN 881239 8.0 mm x 45 m (5/16" x 150') for Wolf 8.5

PN 880106 9.5 mm x 30.5 m (3/8" x 100') for Wolf 12.0



Wire Rope w/o Hook

PN 882413 3.6 mm x 18.3 m (9/64" x 60') for GTD-650

PN 882411 4.0 mm x 18.3 m (5/32" x 60') for GTD-800

PN 882410 4.8 mm x 18.3 m (3/16" x 60') for GTD-1200

PN 882484 6.3 mm x 30.5 m (1/4" x 100') for GTD-2200

PN 882487 7.9 mm x 28 m (5/16" x 92') for GTD-2800



Clevis Hook

PN 881997 5/16" for GTD-650/800

PN 881995 3/8" for GTD-1200/2200

PN 881996 1/2" for GTD-2800



Cable Tensioner

PN 882796 345 mm for Bison 50

PN 881983 193 mm for Bison 20/30 Std. drum

PN 882195 345 mm for Bison 20/30 Long drum

PN 881238 184 mm for HV-8 Std. drum

PN 880179 249 mm for HV-8 Long drum, HV-10/12/15

PN 881236 153 mm for Yak 7 Std. drum

PN 881237 233 mm for Yak 7 Long drum

PN 881667 204 mm for Rhino 8

PN 883552 193 mm for Rhino 12/15

PN 880358 222 mm for Wolf 8.5/12.0



Air Clutch

PN 883226 for HV-8/10

PN 883227 for HV-12/15



Extended Clutch Kit

PN 881314 for HV-8/10

PN 883386 for HV-12/15



Over Center Valve

PN 883314 70-210 bar setting for HV-8/10/12/15



Winch Accessory Kit

Heavy Duty Kit **PN 883438**

Designed for winch single line capacity to 6,803 kg / 15,000 lb
Includes:

- 13,610 kg / 30,000 lb maximum capacity snatch block, **PN 881082**
- 100 mm x 2.4 m (4" x 8") tree trunk protector strap, **PN 881091**
- 75 mm x 9 m (3" x 30") tow strap rated to 9,800 kg/21,600 lb, **PN 881090**
- Bow shackle, 33 mm (3/4") pin diameter, **PN 883440**
- 3 m of 8 mm (10' of 5/16") grade 70 choker chain with hooks, **PN 881096**
- Gloves, **PN 883437**
- Bag, **PN 883439**



Base Plate Bracket

PN 883830 for Bison 50

PN 883831 for Bison 30

PN 883832 for Bison 30 Long drum

PN 883833 for Bison 20

PN 883834 for Bison 20 Long drum



Battery Isolation Switch **PN 881097**

2 Position Off-On 12V 500 Amp for Rhino 8/12, GTD-650/800/1200/2200/2800, Wolf 8.5/12.0



Emergency Stop Switch, PN 881668 400A

Industrial Winch Accessories

Bison/HV/Yak

Series		Hydraulic Winch							
Model Number		Bison 50	Bison 30	Bison 20	HV-15	HV-12	HV-10	HV-8	Yak 7
Gear train		Planetary gears						Worm gears	
Rated line pull	SAE J706 rating	22,680 kg / 50,000	13,600 kg / 30,000 lb	9,070 kg / 20,000 lb	6,800 kg / 15,000 lb	5,440 kg / 12,000 lb	4,535 kg / 10,000 lb	3,630 kg / 8,000 lb	3,175 kg / 7,000 lb
	EN 14492-1rating	-	-	9,070 kg	6,800 kg	5,100 kg	4,300 kg	3,560 kg	3,200 kg
Counterbalance or over-center valve		●	●	●	●	●	●	●	●
Roller fairlead for	Std. drum	●	●	●	●	●	●	●	●
	for Long drum	-	●	●	-	-	-	●	●
Cable tensioner for	Std. drum	●	●	●	⊙	⊙	⊙	⊙	⊙
	for Long drum	-	●	●	-	-	-	⊙	⊙
Air clutch		built-in	built-in	built-in	⊙	⊙	⊙	⊙	-
Snatch block		⊙	⊙	⊙	⊙	⊙	⊙	⊙	⊙

Rhino/Wolf/GTD

Series		Electric recovery Winch						Heavy Duty Hoist						
Model Number		Rhino 15 Pro	Rhino 15	Rhino 12 Pro	Rhino 12	Rhino 8 Pro	Rhino 8	Wolf 12.0	Wolf 8.5	GTD-2800	GTD-2200	GTD-1200	GTD-800	GTD-650
Gear train		Planetary gears						Worm gears		Planetary gears				
Rated line pull or lift		6,800 kg / 15,000 lb		5,440 kg / 12,000 lb		3,630 kg / 8,000 lb		5,443 kg / 3,856 kg / 12,000 lb 8,500 lb		1,270 kg/ 2,800 lb	998 kg/ 2,200 lb	544 kg / 1,200 lb	362 kg / 800 lb	295 kg / 650 lb
Remote control		●	●	●	●	●	●	●	●	●	●	●	●	●
Control box	12V	-	-	●	●	●	●	●	●	●	●	●	●	●
	24V	●	●	●	●	●	●	●	●	●	●	●	●	●
Wire rope w/hook		⊙	⊙	⊙	⊙	⊙	⊙	●	●	●	●	●	●	●
Roller fairlead		●	●	●	●	●	●	●	●	-	-	-	-	-
Battery lead		●	●	●	●	●	●	●	●	●	●	●	●	●
Cable tensioner		⊙	⊙	⊙	⊙	⊙	⊙	●	●	-	-	-	-	-
Snatch block		⊙	⊙	⊙	⊙	⊙	⊙	⊙	⊙	⊙	⊙	⊙	⊙	⊙
ICB (Intelligent Control Box)		●	-	●	-	●	-	-	-	-	-	-	-	-

● Means as a standard accessory / ⊙ Means as an option accessory



HYDRAULIC HOIST for Mobile Crane Vehicle

APE Series / 900 - 1,200 - 1,600 - 1,900 kg lifting capacity

- Internally lubricated for reliable power and an exceptionally long service life.
- Compact, hardened and high efficiency gear trains reduce power loss and placed inside the drum.
- Multi-Disc Brake (MDB) patented and two way counter-balance valve together for holding full load.
- The normal lifting capacity is rated at the top layer of wire rope. It always lifts its rated load no matter what layer of wire rope it is.
- The drum is dimensioned to obtain a minimum D/d ratio of 18:1 with a 5:1 minimum safety factor at the rated load.
- The hoist meets the requirement of FEM9.511 covering rating and classification and FEM 1001 standard for the calculation of lifting equipment.
- Compliance with international standards such as ASME B30.7 and, CE Machinery Directive 2006/42/EC and EN 14492-2 : 2006 Power Driven Hoists.



APE 19/16

1,900/1,600 KG Hydraulic Hoist for Mobile Crane

• Meets ASME B30.7 and, CE Machinery Directive 2006/42/EC standards

APE 19 PN 681930 Std. drum | PN 681940 Long drum

APE 16 PN 681920



SPECIFICATIONS :

Rated line lift :

APE 19 : 1,900 kg (4,190 lb) single line at the top layer of rope

APE 16 : 1,600 kg (3,527 lb) single line at the top layer of rope

Motor :

APE 19 : 200 cm³/rev (12.2 in³/rev)

APE 16 : 159.7 cm³/rev (9.7 in³/rev)

Operation pressure : 205 bar (2,973 psi) with maximum back pressure on return line of 5 bar

Max-Min pump flow :

APE 19 : 60 - 20 l/min (15.9 - 5.3 g/min)

APE 16 : 45 - 15 l/min (11.9 - 4.0 g/min)

Gear train & ratio : 1-stage planetary 5.8:1

Brake : Multi-Disc Brake (MDB) patented and counter-balance valve together

Hoist construction : Steel housings with steel drum

Hoist Rotation : Counter clockwise rotation of the drum

Drum size (dXDXL) :

APE 19 (Std. drum) /16 : 210 x 344 x 191 mm (8.3" x 13.5" x 7.5")

APE 19 (Long drum) : 210 x 344 x 320 mm (8.3" x 13.5" x 12.6")

Recommended wire rope :

APE 19 : 12 mm x 48 m for std. drum and 12 mm x 82 m for long drum with 1,960 N/mm² grade with minimum breaking strength of 100 kN for EN 14492-2 rating

1/2" x 157' for std. drum and 1/2" x 269' for long drum with EIPS grade with minimum breaking strength of 22,487 lbf for ASME B30.7 rating

APE 16 : 10 mm x 57 m with 2,160 N/mm² grade with minimum breaking strength of 78.2 kN for EN 14492-2 rating

3/8" x 187' with EIPS grade with minimum breaking strength of 17,593 lbf for ASME B30.7 rating

Mounting bolt pattern :

APE 19 (Std. drum) / 16 : 290 x 196 mm (11.4" x 7.7")

APE 19 (Long drum) : 290 x 325 mm (11.4" x 12.8")

Hoist weight : APE 19 (Std. drum) : 88 kg / 194 lb

APE 19 (Long drum) : 101 kg / 223 lb

APE 16 : 87 kg / 192 lb

Gross weight : APE 19 (Std. drum) : 106 kg / 234 lb

APE 19 (Long drum) : 123 kg / 271 lb

APE 16 : 105 kg / 232 lb

Box dimension, (L x D x H) :

APE 19 (Std. drum) / 16 : 490 x 490 x 600 mm (19.3" x 19.3" x 23.6")

APE 19 (Long drum) : 620 x 510 x 600 mm (24.4" x 20.1" x 23.6")

PERFORMANCE DATA :

Line Lift and Rope Capacity

APE 19

Layer of Wire Rope	Lift by Layer, kg / lb	Line Speed, mpm / fpm	Total Rope on the Drum, m / ft	
			Std. drum	Long drum
1 st	2,515 / 5,545	35.0 / 115	10.4 / 34	18 / 59
2 nd	2,270 / 5,004	38.8 / 127	22 / 72	38 / 124
3 rd	2,068 / 4,559	42.6 / 140	35 / 114	60 / 195
4 th	1,900 / 4,190	46.4 / 153	48 / 157	82 / 269

APE 16

Layer of Wire Rope	Lift by Layer, kg / lb	Line Speed, mpm / fpm	Total Rope on the Drum, m / ft
			m / ft
1 st	2,036 / 4,489	33.8 / 111	12.5 / 41
2 nd	1,866 / 4,141	36.8 / 121	26.2 / 86
3 rd	1,723 / 3,796	40 / 131	41 / 134
4 th	1,600 / 3,527	43 / 141	57 / 187

The total rope on the drum may vary from figures stated elsewhere

DIMENSION mm/in :

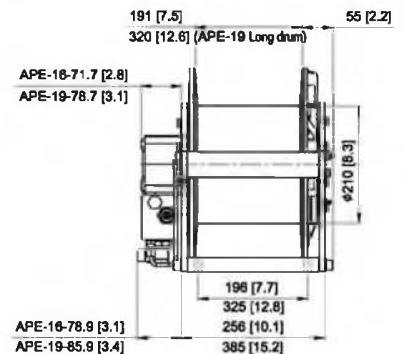
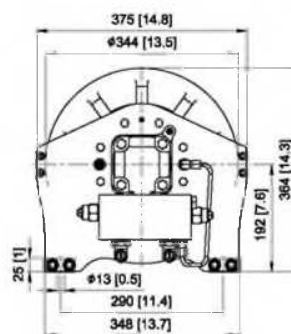

- Option Accessories
- Cable tensioner
 - Wire rope with hook
 - Up and Down limit protection device

1,200/900 KG Hydraulic Hoist for Mobile Crane

• Meets ASME B30.7 and, CE Machinery Directive 2006/42/EC standards

APE 12 PN 681910 | APE 9 PN 681900



DIMENSION mm/in :

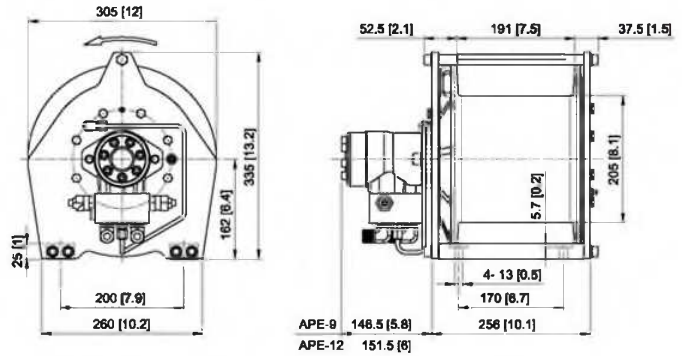

SPECIFICATIONS :

Rated line lift :

APE 12 : 1,200 kg (2,640 lb) single line at the top layer of rope

APE 9 : 900 kg (1,984 lb) single line at the top layer of rope

Motor :

APE 12 : 194.6 cm³/rev (11.9 in³/rev)

APE 9 : 155.7 cm³/rev (9.5 in³/rev)

Operation pressure :

APE 12 : 150 bar (2,176 psi) with maximum back pressure on return line of 5 bar

APE 9 : 140 bar (2,031 psi) with maximum back pressure on return line of 5 bar

Max-Min pump flow :

APE 12 : 40 - 20 l/min (10.6 - 5.3 g/min)

APE 9 : 35 - 15 l/min (9.2 - 4.0 g/min)

Gear train & ratio : 1-stage planetary 5:1

Brake : Multi-Disc Brake (MDB) patented and counter-balance valve together

Hoist construction : Steel housings with steel drum

Hoist Rotation : Counter clockwise rotation of the drum

Drum size (dXDXL) : 205 x 305 x 191 mm (8.1" x 12.0" x 7.5")

Recommended wire rope :

APE 12 : 10 mm x 55 m with 1,960 N/mm² grade with minimum breaking strength of 69.8 kN for EN 14492-2 rating

3/8" x 180' with EIPS grade with minimum breaking strength of 15,663 lbf for ASME B30.7 rating

APE 9 : 8 mm x 68 m with 1,960 N/mm² grade with minimum breaking strength of 44.7 kN or EN 14492-2 rating

5/16" x 223' with EIPS grade with minimum breaking strength of 10,003 lbf for ASME B30.7 rating

Mounting bolt pattern : 200 x 170 mm (7.9" x 6.7")

Hoist weight : APE 12 : 64 kg / 141 lb

APE 9 : 63 kg / 140 lb

Gross weight : APE 12 : 81 kg / 179 lb

APE 9 : 80 kg / 176 lb

Box dimension, (L x D x H) : 550 x 440 x 570 mm (21.7" x 17.3" x 22.4")

PERFORMANCE DATA :

Line Lift and Rope Capacity

APE 12

Layer of Wire Rope	Lift by Layer, kg / lb	Line Speed, mpm / fpm	Total Rope on the Drum, m / ft
1 st	1,535 / 3,384	27.8 / 91	12.2 / 40
2 nd	1,404 / 3,094	30.4 / 100	25.6 / 84
3 rd	1,294 / 2,853	33 / 108	40 / 131
4 th	1,200 / 2,645	35.5 / 116	55 / 180

APE 9

Layer of Wire Rope	Lift by Layer, kg / lb	Line Speed, mpm / fpm	Total Rope on the Drum, m / ft
1 st	1,100 / 2,425	30.1 / 99	15 / 50
2 nd	1,023 / 2,255	32.3 / 106	31.8 / 104
3 rd	956 / 2,108	34.6 / 114	49.4 / 162
4 th	900 / 1,984	37 / 121	68 / 223

The total rope on the drum may vary from figures stated elsewhere

- ▶ Option Accessories
- Cable tensioner
 - Wire rope with hook
 - Up and Down limit protection device



ENGINEERING DATA

Maximum Line Pull

This is the maximum dead-weight the winch could lift off the ground with a single line on the first layer of wire rope on the drum. They are not suitable for vertical lifting.

Winching Principles

You need a winch to be powerful enough to pull your vehicle while overcome the added resistance caused by the obstacle, moving water, mud, snow, sand or on a steep hill.

As a general guide you need a winch with a maximum line pull of at least 1.5 times greater than the gross vehicle weight. There are three factors have influenced with the line pull effect required to recover the vehicle. The values and calculations in this section are approximate and are for reference only.

1. Gross Vehicle Weight (Wt): Contains the vehicle weight and the weight of the supplies and equipments carried.

2. Surface Drag (S): The characteristics of the terrains or surface to be traversed

Surface Type	Metal	Sand	Gravel	Soft Sand	Mud	Marsh	Clay
Surface Drag (S)	0.15	0.18	0.20	0.22	0.32	0.52	0.52

3. Gradient Resistance: The incline of grade or slope on which the vehicle is being moved.

Gradient	5%	10%	20%	30%	50%	70%	100%
Angle (ref.)	30	60	110	170	26%	35%	45%
Gradient (G)	0.06	0.11	0.2	0.3	0.44	0.58	0.7

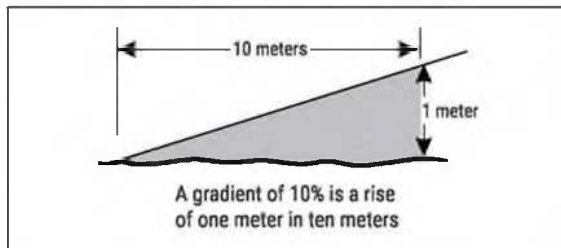

Rolling Pull Effect Required = (Wt x S) + (Wt x G)

For example, if a vehicle weighing 3,000 kg is winched up an incline by 100% on the marsh road, the above formula would be used as follows:

Where

Wt : 3,000 kg (gross vehicle weight)

S : 0.52 (co-efficient for marsh)

G : 0.71 (gradient value of 100%)

(Wt x S) + (Wt x G) = (3,000 kg x 0.52) + (3,000 kg x 0.71)

= 1,560 kg + 2,130 kg = 3,690 kg of effect required to recover the vehicle

Winch / Load Rated

• Load and speed varies according to how much wire rope is on the drum. The first layer of rope on the drum delivers the slowest speed and the maximum load. The top layer of rope on the drum delivers the maximum speed and the minimum load. For this reason, all AUTOMOTIVE, POWERSPORTS and INDUSTRIAL winches are rated at their first layer capacities.

Hydraulic Hoist / Load Rated

• Load and speed varies according to how much wire rope is on the drum. The first layer of rope on the drum delivers the slowest speed and the maximum load. The top layer of rope on the drum delivers the maximum speed and the minimum load. For this reason, all hoists are rated at their top layer capacities.

• Leave two free layers below the top of the drum flanges to meet European lifting rules

• Leave a minimum of ½ inch (13 mm) below the top of the drum flange to meet ASME 30.7

DUTY CYCLE RATINGS

S1 Continuous Duty

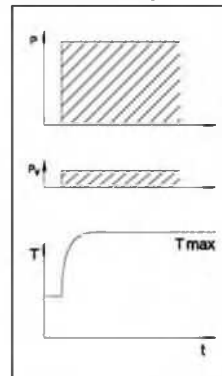

The motor works at a constant load for enough time to reach temperature equilibrium

P load
Pv electrical losses
T temperature

S2 Short Time Duty

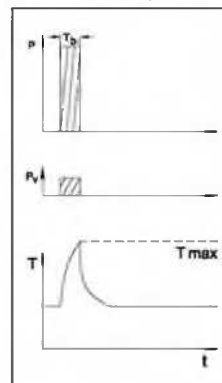

The motor works at a constant load, but not long enough to reach temperature equilibrium, and the rest periods are long enough for the motor to reach ambient temperature

Examples: S2 - 60 min (The time means 60 minutes rating)

Tmax maximum temperature
Tb time of operation

S3 Intermittent Periodic Duty

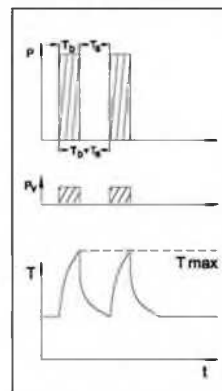

Sequential, identical run and rest cycles with constant load. Temperature equilibrium is never reached. Starting current has little effect on temperature rise.

Example: S3 - 5% (The percent figure refers to the cyclic duration factor)

Tb time of operation
Ts time of rest

$$ED\% = \frac{T_b}{T_b + T_s} \times 100\%$$

Tb + Ts = approximately 1 to 10 minutes

For this reason, all Automotive, Industrial and Powersports winches are rated at S3 Intermittent periodic duty.

Алматы (7273)495-231
Ангарск (3956)60-70-56
Архангельск (8182)63-90-72
Астрахань (8512)99-46-04
Барнаул (3852)73-04-60
Белгород (4722)40-23-64
Благовещенск (4162)22-76-07
Брянск (4832)59-03-52
Владивосток (423)249-28-31
Владикавказ (8672)28-90-48
Владимир (4922)49-43-18
Волгоград (844)278-03-48
Вологда (8172)26-41-59
Воронеж (473)204-51-73
Екатеринбург (343)384-55-89

Иваново (4932)77-34-06
Ижевск (3412)26-03-58
Иркутск (395)279-98-46
Казань (843)206-01-48
Калининград (4012)72-03-81
Калуга (4842)92-23-67
Кемерово (3842)65-04-62
Киров (8332)68-02-04
Коломна (4966)23-41-49
Кострома (4942)77-07-48
Краснодар (861)203-40-90
Красноярск (391)204-63-61
Курск (4712)77-13-04
Курган (3522)50-90-47
Липецк (4742)52-20-81

Магнитогорск (3519)55-03-13
Москва (495)268-04-70
Мурманск (8152)59-64-93
Набережные Челны (8552)20-53-41
Нижний Новгород (831)429-08-12
Новокузнецк (3843)20-46-81
Новосибирск (383)227-86-73
Омск (3812)21-46-40
Орел (4862)44-53-42
Оренбург (3532)37-68-04
Пенза (8412)22-31-16
Петрозаводск (8142)55-98-37
Псков (8112)59-10-37
Пермь (342)205-81-47

Ростов-на-Дону (863)308-18-15
Рязань (4912)46-61-64
Самара (846)206-03-16
Санкт-Петербург (812)309-46-40
Саратов (845)249-38-78
Севастополь (8692)22-31-93
Саранск (8342)22-96-24
Симферополь (3652)67-13-56
Смоленск (4812)29-41-54
Сочи (862)225-72-31
Ставрополь (8652)20-65-13
Сургут (3462)77-98-35
Сыктывкар (8212)25-95-17
Тамбов (4752)50-40-97
Тверь (4822)63-31-35

Тольятти (8482)63-91-07
Томск (3822)98-41-53
Тула (4872)33-79-87
Тюмень (3452)66-21-18
Ульяновск (8422)24-23-59
Улан-Удэ (3012)59-97-51
Уфа (347)229-48-12
Хабаровск (4212)92-98-04
Чебоксары (8352)28-53-07
Челябинск (351)202-03-61
Череповец (8202)49-02-64
Чита (3022)38-34-83
Якутск (4112)23-90-97
Ярославль (4852)69-52-93

Россия +7(495)268-04-70

Казахстан +7(7172)727-132

Киргизия +996(312)96-26-47