

### Introduction

#### ► Feature

Line pull:	3,630 kg / 8,000 lb synthetic rope first layer
Synthetic rope:	8 mm × 30.5 m (5/16"×100') synthetic rope
Brake:	Exclusive brake design with No. 37C device
Clutch:	Turn the mechanism lever for rapid rope payout
Control:	Handheld pendant switch powers the winch

#### ► Unpacking

• Winch assembly.....	1 pc
• Control box.....	1 pc
• Remote control.....	1 pc
• Synthetic rope with clevis hook.....	1 pc
• Hawse fairlead.....	1 pc
• 1.8 m (6') 2 gauge battery lead.....	1 pc

#### ► Read this manual carefully

You should carefully read and understand this manual before operating it. Careless winch operation may result in personal injury hazards or property damage.

### Installation

Before using the winch, make sure all electrical components have no corrosion or damaged; the environment should be clear and dry.

#### ► Winch and hawse fairlead mountings

- It is very important that the winch will be mounted on a flat and hard surface of mounting channel in order to make sure the motor, drum and gearbox housing are aligned correctly.

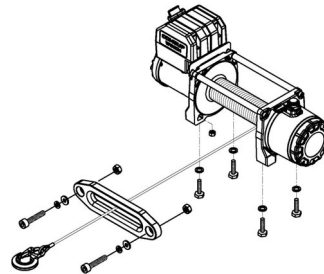

- Hawse fairlead does not mount to the winch directly.
- The synthetic rope shall be wound in an under-wound orientation only.
- Four (4) M10 x 1.50 pitch 8.8 grade with 44 N-m torque settings (maximum) high tensile steel bolts must be used in order to sustain the loads imposed on the winch mounting.
- Two (2) M10 x 1.50 pitch 8.8 grade with 44 N-m torque settings (maximum) high tensile steel bolts must be used for fastening the roller fairlead into the mounting channel.

#### ► Wiring Diagram

- Connect control ground to the motor.
- Attach the ground lead firmly to the negative (-) battery terminal and power lead to the positive (+) battery terminal. The voltage drop for the winch motor must not exceed 10% of the nominal voltage of 12V DC.

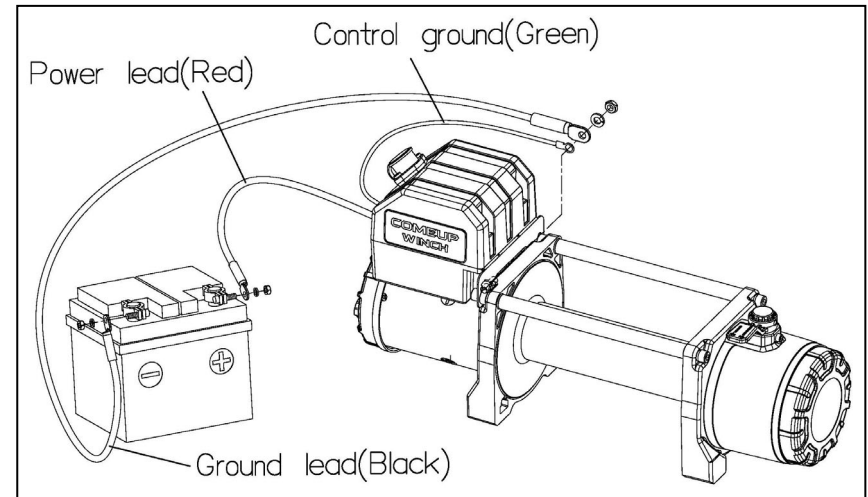

#### ► Nut fastening for motor & contactor

1. Holding the lower nut on the stub and fastening the upper nut clockwise.
2. The torque setting for nut is 14 N-m/124 lb-in.

Алматы (7273)495-231  
 Ангарск (3955)60-70-56  
 Архангельск (8182)63-90-72  
 Астрахань (8512)99-46-04  
 Барнаул (3852)73-04-60  
 Белгород (4722)40-23-64  
 Благовещенск (4162)22-76-07  
 Брянск (4832)59-03-52  
 Владивосток (423)249-28-31  
 Владикавказ (8672)28-90-48  
 Владимир (4922)49-43-18  
 Волгоград (844)278-03-48  
 Вологда (8172)26-41-59  
 Воронеж (473)204-51-73  
 Екатеринбург (343)384-55-89

Иваново (4932)77-34-06  
 Ижевск (3412)26-03-58  
 Иркутск (395)279-98-46  
 Казань (843)206-01-48  
 Калининград (4012)72-03-81  
 Калуга (4842)92-23-67  
 Кемерово (3842)65-04-62  
 Киров (8332)68-02-04  
 Коломна (4966)23-41-49  
 Кострома (4942)77-07-48  
 Краснодар (861)203-40-90  
 Красноярск (391)204-63-61  
 Курск (4712)77-13-04  
 Курган (3522)50-90-47  
 Липецк (4742)52-20-81

Магнитогорск (3519)55-03-13  
 Москва (495)268-04-70  
 Мурманск (8152)59-64-93  
 Набережные Челны (8552)20-53-41  
 Нижний Новгород (831)429-08-12  
 Новокузнецк (3843)20-46-81  
 Ноябрьск (3496)41-32-12  
 Новосибирск (383)227-86-73  
 Омск (3812)21-46-40  
 Орел (4862)44-53-42  
 Оренбург (3532)37-68-04  
 Пенза (8412)22-31-16  
 Петрозаводск (8142)55-98-37  
 Псков (8112)59-10-37  
 Пермь (342)205-81-47

Ростов-на-Дону (863)308-18-15  
 Рязань (4912)46-61-64  
 Самара (846)206-03-16  
 Санкт-Петербург (812)309-46-40  
 Саратов (845)249-38-78  
 Севастополь (8692)22-31-93  
 Саранск (8342)22-96-24  
 Симферополь (3652)67-13-56  
 Смоленск (4812)29-41-54  
 Сочи (862)225-72-31  
 Ставрополь (8652)20-65-13  
 Сургут (3462)77-98-35  
 Сыктывкар (8212)25-95-17  
 Тамбов (4752)50-40-97  
 Тверь (4822)63-31-35

Тольятти (8482)63-91-07  
 Томск (3822)98-41-53  
 Тула (4872)33-79-87  
 Тюмень (3452)66-21-18  
 Ульяновск (8422)24-23-59  
 Улан-Удэ (3012)59-97-51  
 Уфа (347)229-48-12  
 Хабаровск (4212)92-98-04  
 Чебоксары (8352)28-53-07  
 Челябинск (351)202-03-61  
 Череповец (8202)49-02-64  
 Чита (3022)38-34-83  
 Якутск (4112)23-90-97  
 Ярославль (4852)69-52-93

Россия +7(495)268-04-70

Казахстан +7(7172)727-132

Киргизия +996(312)96-26-47

## Warning

- The winch is not intended to be used in any manner for the movement or lifting of personnel.
- The rated line pull shown is based on the first layer of rope on the drum.
- The rope winding on the drum shall remain 10 wraps from the drum to support the rated load.
- Manufacturer is not responsible for the results of misuse, misapplication, faulty installation or abuse of synthetic rope in any way.

## Parts List

Item No.	Description	Part No.	Qty
1	Waterproof motor w/housing 12V	883201	1
2	Tie bar kit	883641	2
3	Brake clutch base kit	883206	1
4	Drum bushing	880006	2
5	Drum kit	884090	1
6	Cone brake disc kit	883208	1
7	Gearbox support rack	883209	1
8	Grounding lead	883210	1
9	Synthetic rope	883271	1
10	1 <sup>st</sup> shaft	883214	1
11	ring gear kit	883215	1
12	3 <sup>rd</sup> stage carrier	883216	1
13	2 <sup>nd</sup> stage carrier	883217	1
14	1 <sup>st</sup> stage carrier	883218	1
15	1 <sup>st</sup> pinion	883219	1
16	Clutch kit	883220	1
17	Gear box kit	883221	1
18	Hawse fairlead	883622	1
19	Mounting hardware	883223	1
20	Remote control	880025	1
21	Handsaver strap	880026	1
22	Control box 12V	883637	1
22-1	Remote socket kit	883235	1
22-2	Control pack 12V	883639	1
23	Clevis hook	881997	1

## Winch Assembly

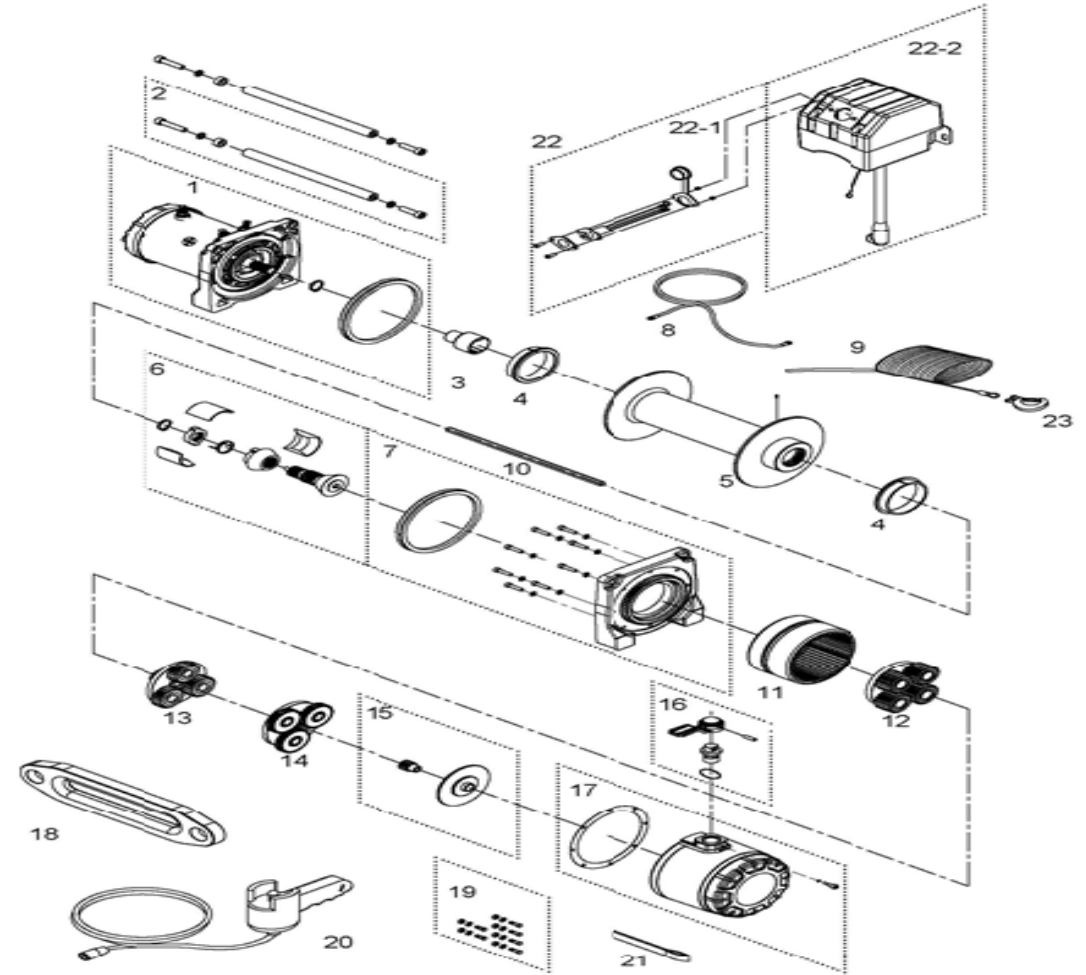

Алматы (7273)495-231  
 Ангарск (3955)60-70-56  
 Архангельск (8182)63-90-72  
 Астрахань (8512)99-46-04  
 Барнаул (3852)73-04-60  
 Белгород (4722)40-23-64  
 Благовещенск (4162)22-76-07  
 Брянск (4832)59-03-52  
 Владивосток (423)249-28-31  
 Владикавказ (8672)28-90-48  
 Владимир (4922)49-43-18  
 Волгоград (844)278-03-48  
 Вологда (8172)26-41-59  
 Воронеж (473)204-51-73  
 Екатеринбург (343)384-55-89

Иваново (4932)77-34-06  
 Ижевск (3412)26-03-58  
 Иркутск (395)279-98-46  
 Казань (843)206-01-48  
 Калининград (4012)72-03-81  
 Калуга (4842)92-23-67  
 Кемерово (3842)65-04-62  
 Киров (8332)68-02-04  
 Коломна (4966)23-41-49  
 Кострома (4942)77-07-48  
 Краснодар (861)203-40-90  
 Красноярск (391)204-63-61  
 Курск (4712)77-13-04  
 Курган (3522)50-90-47  
 Липецк (472)52-20-81

Россия +7(495)268-04-70

Магнитогорск (3519)55-03-13  
 Москва (495)268-04-70  
 Мурманск (8152)59-64-93  
 Набережные Челны (8552)20-53-41  
 Нижний Новгород (831)429-08-12  
 Новокузнецк (3843)20-46-81  
 Ноябрьск (3496)41-32-12  
 Новосибирск (383)227-86-73  
 Омск (3812)21-46-40  
 Орел (4862)44-53-42  
 Оренбург (3532)37-68-04  
 Пенза (8412)22-31-16  
 Петрозаводск (8142)55-98-37  
 Псков (8112)59-10-37  
 Пермь (342)205-81-47

Казахстан +7(7172)727-132

Ростов-на-Дону (863)308-18-15  
 Рязань (4912)46-61-64  
 Самара (846)206-03-16  
 Санкт-Петербург (812)309-46-40  
 Саратов (845)249-38-78  
 Севастополь (8692)22-31-93  
 Саранск (8342)22-95-24  
 Симферополь (3652)67-13-56  
 Смоленск (4812)29-41-54  
 Сочи (862)225-72-31  
 Ставрополь (8652)20-65-13  
 Сургут (3462)77-98-35  
 Сыктывкар (8212)25-95-17  
 Тамбов (4752)50-40-97  
 Тверь (4822)63-31-35

Киргизия +996(312)96-26-47

Тольятти (8482)63-91-07  
 Томск (3822)98-41-53  
 Тула (4872)33-79-87  
 Тюмень (3452)66-21-18  
 Ульяновск (8422)24-23-59  
 Улан-Удэ (3012)59-97-51  
 Уфа (347)229-48-12  
 Хабаровск (4212)92-98-04  
 Чебоксары (8352)28-53-07  
 Челябинск (351)202-03-61  
 Череповец (8202)49-02-64  
 Чита (3022)38-34-83  
 Якутск (4112)23-90-97  
 Ярославль (4852)69-52-93