

Introduction

► Feature

- Line pull: 6,804 kg / 15,000 lb single line (EN 14492-1 rating)
- Brake: Automatic, full load cone brake
- Clutch: Turn the T-handle for rapid wire rope payout
- Control: Handheld pendant switch powers the winch
- Recommended * 14 mm x 22 m, 1,960 N/mm² grade with a minimum breaking strength of 137 KN required for EN 14492-1 rating

Installation

Before using the winch, make sure all electrical components have no corrosion or damaged; the environment should be clear and dry.

► Mounting

- Winch shall be mounted on a flat and hard surface.
- Winch should be mounted as closed to center and as horizontal as possible to the direction of the line pull.
- Wire rope shall be wound in an under-wound orientation only.
- Eight (8) M12 X 1.75 pitch 8.8 grade w/76 N-m torque setting (maximum) high tensile steel bolts must be used in order to sustain the loads imposed on the winch mounting.
- Two (2) M12 x 1.75 pitch 8.8 grade w/76 N-m torque setting (maximum) high tensile steel bolts must be used for fastening the roller fairlead into the mounting channel.
- It is always preferred to use both tie bars in the final installed configuration.

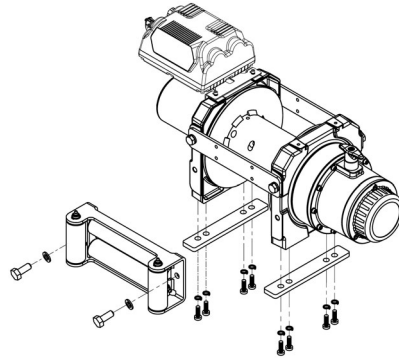

Алматы (7273)495-231
Ангарск (3955)60-70-56
Архангельск (8182)63-90-72
Астрахань (8512)99-46-04
Барнаул (3852)73-04-60
Белгород (4722)40-23-64
Благовещенск (4162)22-76-07
Брянск (4832)59-03-52
Владивосток (423)249-28-31
Владикавказ (8672)28-90-48
Владимир (4922)49-43-18
Волгоград (844)278-03-48
Волгодд (8172)26-41-59
Воронеж (473)204-51-73
Екатеринбург (343)384-55-89

Иваново (4932)77-34-06
Ижевск (3412)26-03-58
Иркутск (395)279-98-46
Казань (843)206-01-48
Калининград (4012)72-03-81
Калуга (4842)92-23-67
Кемерово (3842)65-04-62
Київ (8332)69-02-04
Коломна (4966)23-41-49
Кострома (4942)77-07-48
Краснодар (861)203-40-90
Красноярск (391)204-63-61
Курск (4712)77-13-04
Курган (3522)50-90-47
Липецк (4742)52-20-81
Россия +7(495)268-04-70

Магнитогорск (3519)55-03-13
Москва (495)268-04-70
Мурманск (8152)59-64-93
Набережные Челны (8552)20-53-41
Нижний Новгород (831)429-08-12
Новокузнецк (3843)20-46-81
Новосибирск (383)227-86-73
Омск (3812)21-46-40
Орел (4862)44-53-42
Оренбург (3532)37-68-04
Пенза (8412)22-31-16
Петрозаводск (8142)55-98-37
Псков (8112)59-10-37
Пермь (342)205-81-47
Казахстан +7(7172)727-132

Ростов-на-Дону (863)308-18-15
Рязань (4912)46-61-64
Самара (846)206-03-16
Санкт-Петербург (812)309-46-40
Саратов (845)249-38-78
Севастополь (8692)22-31-93
Саранск (8342)22-95-24
Симферополь (3652)67-13-56
Смоленск (4812)29-41-54
Сочи (862)225-72-31
Ставрополь (8652)20-65-13
Сургут (3462)77-98-35
Сыктывкар (8212)25-95-17
Тамбов (4752)50-40-97
Тверь (4822)63-31-35
Киргизия +996(312)96-26-47

Тольятти (8482)63-91-07
Томск (3822)98-41-53
Тула (4872)33-79-87
Тюмень (3452)66-21-18
Ульяновск (8422)24-23-59
Улан-Удэ (3012)59-97-51
Уфа (347)229-48-12
Хабаровск (4212)92-98-04
Чебоксары (8352)28-53-07
Челябинск (351)202-03-61
Череповец (8202)49-02-64
Чита (3022)38-34-83
Якутск (4112)23-90-97
Ярославль (4852)69-52-93

- * Rope drives with steel wire rope shall be dimensioned
 - * At least 2:1 wire rope working coefficient for the first rope layer.
 - * At least 10:1 D/d ratio to the centre of the rope
 - * Drum freeboard shall be at least 1.5 x rope diameter.
3. The wire rope must be painted red for 1.6 m on both ends and at least five (5) wraps of wire rope remained around the drum to comply with EN ratings;
 - * At least two rope windings on the drum.
 - * Rope attachment to withstand 2.5 x the remaining static force.
 4. Fit an emergency stop switch to comply with emergency stop function.
 5. Fit a hook with a safety latch to comply with a safety hook.

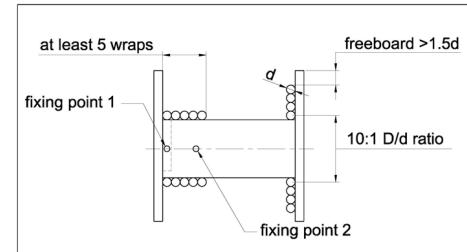

► Wiring Diagram

- Connect thermal sensor harness plug, control ground, and cable A/F1/F2 to the motor.
- Attach the ground lead firmly to the negative (-) battery terminal and power lead to the positive (+) battery terminal. The voltage drop for the winch motor must not exceed 10% of the nominal voltage of 24V DC.
- The over-load protector built in the control box shall be manually reset after reducing the load.
- Always cover the socket with waterproof cap when not in use to prevent ingress of water or foreign objects.
- Installing ICB control box, it is necessary to install a fuse or battery isolation switch as additional protection.

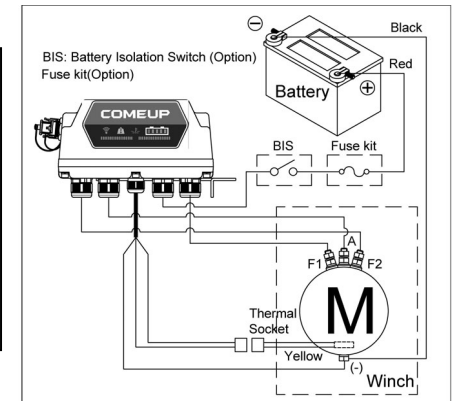
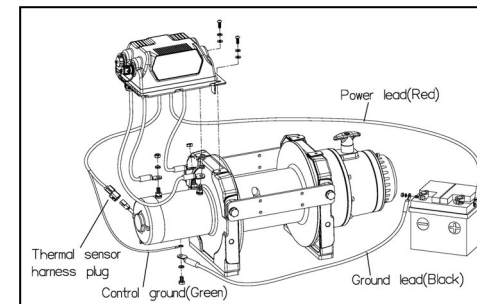

Warning

- The winch is not intended to be used in any manner for the movement or lifting of personnel.
- The rated line pull shown is based on the first layer of rope on the drum for the winch only, consult the wire rope manufacturer for wire rope rating.
- The rope winding on the drum shall remain 5 wraps from the drum.

Parts List

Item No.	Description	Part No.	Qty
1	Motor 24V	883448	1
2	Tie bar kit	883449	2
3	Motor support rack kit	883450	1
4	Motor coupling	880047	1
5	Drum bushing	880048	2
6	Drum kit	883451	1
7	Gearbox support rack	883452	1
8	Grounding lead	880009	1
9	1 st shaft	880053	1
10	3 rd ring gear kit	882436	1
11	3 rd stage carrier kit	881944	1
12	2 nd stage carrier kit	881943	1
13	1 st stage carrier kit	880107	1
14	C ring	880058	1
15	1 st & 2 nd ring gear	880059	1
16	1 st pinion kit	880060	1
17	Clutch kit	880061	1
18	Gear box kit	882437	1
19	Brake base	882438	1
20	Cone brake disc kit	880021	1
21	Brake cover kit	882423	1
22	Roller fairlead	882481	1
23	Mounting hardware	883453	1
24	Remote control	883509	1
25	Control box 24V	883521	1
26	Brake clutch base	881434	1

Алматы (7273)495-231
 Ангарск (3955)60-70-56
 Архангельск (8182)63-90-72
 Астрахань (8512)99-46-04
 Барнаул (3852)73-04-60
 Белгород (4722)40-23-64
 Благовещенск (4162)22-76-07
 Брянск (4832)59-03-52
 Владивосток (423)249-28-31
 Владикавказ (8672)28-90-48
 Владимир (4922)49-43-18
 Волгоград (844)278-03-48
 Вологда (8172)26-41-59
 Воронеж (473)204-51-73
 Екатеринбург (343)384-55-89

Иваново (4932)77-34-06
 Ижевск (3412)26-03-58
 Иркутск (395)279-98-46
 Казань (843)206-01-48
 Калининград (4012)72-03-81
 Калуга (4842)92-23-67
 Кемерово (3842)65-04-62
 Киров (8332)68-02-04
 Коломна (4966)23-41-49
 Кострома (4942)77-07-48
 Краснодар (861)203-40-90
 Красноярск (391)204-63-61
 Курск (4712)77-13-04
 Курган (3522)50-40-97
 Липецк (4742)52-20-81
 Россия +7(495)268-04-70

Магнитогорск (3519)55-03-13
 Москва (495)268-04-70
 Мурманск (8152)59-64-93
 Набережные Челны (8552)20-53-41
 Нижний Новгород (831)429-08-12
 Новокузнецк (3843)20-46-81
 Ноябрьск (3496)41-32-12
 Новосибирск (383)227-86-73
 Омск (3812)21-46-40
 Орел (4862)44-53-42
 Оренбург (3532)37-68-04
 Пенза (8412)22-31-16
 Петрозаводск (8142)55-98-37
 Псков (8112)59-10-37
 Пермь (342)205-81-47
 Казахстан +7(7172)727-132

Ростов-на-Дону (863)308-18-15
 Рязань (4912)46-61-64
 Самара (846)206-03-16
 Санкт-Петербург (812)309-46-40
 Саратов (845)249-38-78
 Севастополь (8692)22-31-93
 Саранск (8342)22-96-24
 Симферополь (3652)67-13-56
 Смоленск (4812)29-41-54
 Сочи (862)225-72-31
 Ставрополь (8652)20-65-13
 Сургут (3482)77-98-35
 Сыктывкар (8212)25-95-17
 Тамбов (4522)50-40-97
 Тверь (4822)63-31-35
 Киргизия +996(312)96-26-47

Тольятти (8482)63-91-07
 Томск (3822)98-41-53
 Тула (4872)33-79-87
 Тюмень (3452)66-21-18
 Ульяновск (8422)24-23-59
 Улан-Уда (3012)59-97-51
 Уфа (347)229-48-12
 Хабаровск (4212)92-98-04
 Чебоксары (8352)28-53-07
 Челябинск (351)202-03-61
 Череповец (8202)49-02-64
 Чита (3022)38-34-83
 Якутск (4112)23-90-97
 Ярославль (4852)69-52-93

Winch Assembly

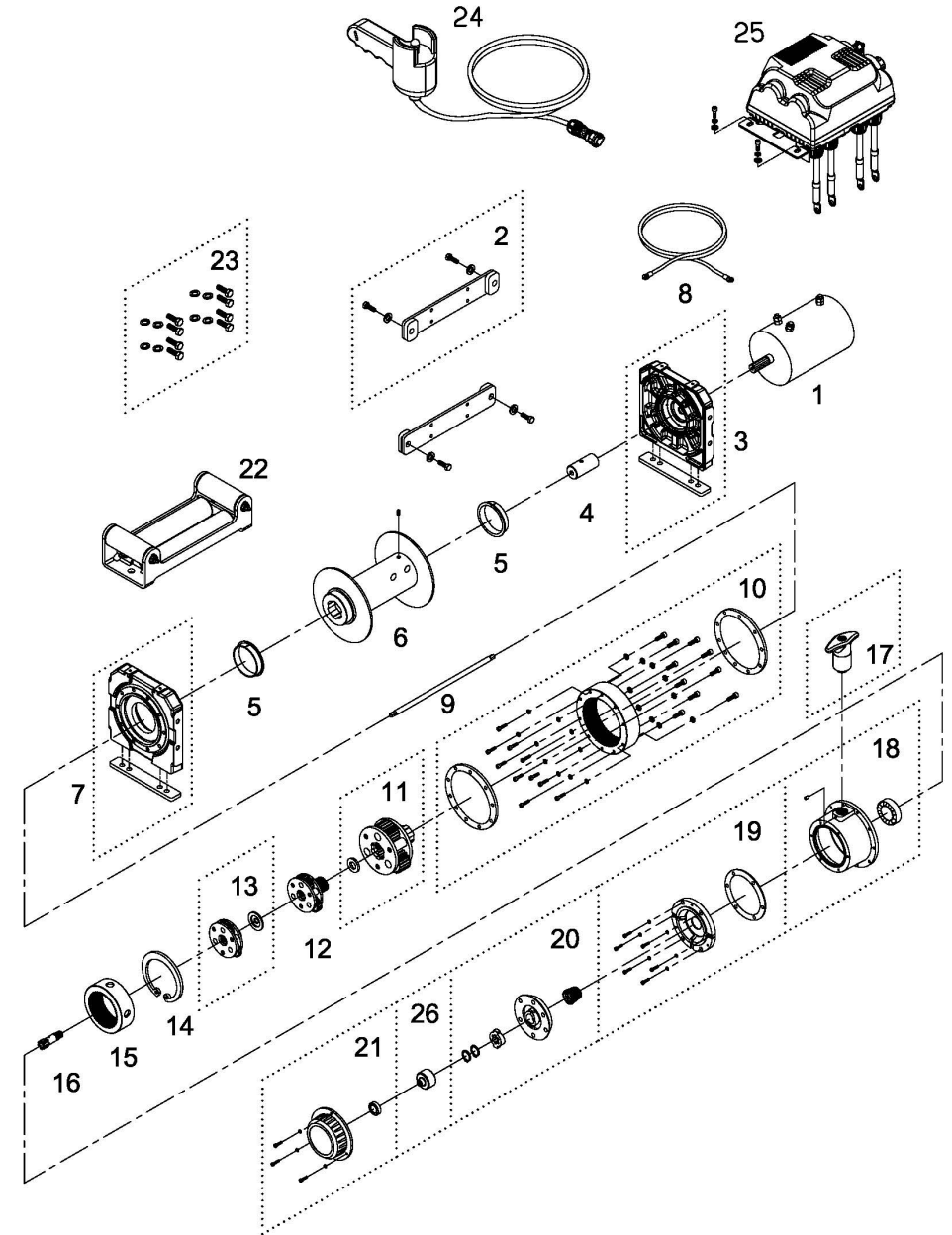

2023/06/15 Ver:03