

PN: 782478 12V  
783415 24V 784598 24V

### Introduction

#### ► Feature

- Line pull: 5,443 kg / 12,00 lb wire rope first layer
- Motor: 12V: 3,430 w / 4.6 hp      24V: 2,240 w / 3.0 hp
- Line speed: **3.1 / 5.0** mpm , **10.1 / 16.4** fpm, 70A/12V, **50A/24V** at no load,  
**0.3 / 0.7** mpm , **1.0 / 2.3** fpm, 350A/12V, **270A/24V** at full
- Brake: Irreversible worm gear brake PLUS mechanism ratchet wheel brake providing 100% braking
- Clutch: Turn the mechanism lever for rapid wire rope payout
- Wire rope: 9.5 mm × 30.5 m (3/8" × 100') galvanized aircraft A7 x 19
- Control: Handheld pendant switch powers the winch

#### ► Unpacking

- Control box..... 1pc
- Remote control..... 1pc
- Wire rope with hook..... 1pc
- Roller fairlead..... 1pc
- Cable tensioner..... 1pc
- 1.8 m ( 6' ) 2 gauge battery leads..... 1pc

#### ► Read this manual carefully

You should carefully read and understand this manual before operating it. Careless winch operation may result in personal injury hazards or property damage.

Алматы (7273)495-231	Иваново (4932)77-34-06	Магнитогорск (3519)55-03-13	Ростов-на-Дону (863)308-18-15	Тольятти (8482)63-91-07
Ангарск (3955)60-70-56	Ижевск (3412)26-03-58	Москва (495)268-04-70	Рязань (4912)46-61-64	Томск (3822)98-41-53
Архангельск (8182)63-90-72	Иркутск (395)279-98-46	Мурманск (8152)69-64-93	Самара (846)206-03-16	Тула (4872)33-79-87
Астрахань (8512)99-46-04	Казань (843)206-01-48	Набережные Челны (8552)20-53-41	Санкт-Петербург (812)309-46-40	Тюмень (3452)66-21-18
Барнаул (3852)73-04-60	Калининград (4012)72-03-81	Нижний Новгород (831)429-08-12	Саратов (845)249-38-78	Ульяновск (8422)24-23-59
Белгород (4722)40-23-64	Калуга (4842)92-23-67	Новокузнецк (3843)20-46-81	Севастополь (8692)22-31-93	Улан-Удэ (3012)59-97-51
Благовещенск (4162)22-76-07	Кемерово (3842)65-04-62	Новобрянск (3496)41-32-12	Саранск (8342)22-96-24	Уфа (347)229-48-12
Брянск (4832)59-03-52	Киров (8332)68-02-04	Новосибирск (383)227-86-73	Симферополь (3652)67-13-56	Хабаровск (4212)92-98-04
Владивосток (423)249-28-31	Коломна (4966)23-41-49	Омск (3812)21-46-40	Смоленск (4812)29-41-54	Чебоксары (8352)28-53-07
Владикавказ (8672)28-90-48	Кострома (4942)77-07-48	Орел (4862)44-53-42	Сочи (862)225-72-31	Челябинск (351)202-03-61
Владимир (4922)49-43-18	Краснодар (861)203-40-90	Оренбург (3532)37-68-04	Ставрополь (8652)20-65-13	Череповец (8202)49-02-64
Волгоград (844)278-03-48	Красноярск (391)204-63-61	Пенза (8412)22-31-16	Сургут (3462)77-98-35	Чита (3022)38-34-83
Вологда (8172)26-41-59	Курск (4712)77-13-04	Петрозаводск (8142)55-98-37	Сыктывкар (8212)25-95-17	Якутск (4112)23-90-97
Воронеж (473)204-51-73	Курган (3522)50-90-47	Псков (8112)59-10-37	Тамбов (4752)50-40-97	Ярославль (4852)69-52-93
Екатеринбург (343)384-55-89	Липецк (4742)52-20-81	Пермь (342)205-81-47	Тверь (4822)63-31-35	

Россия +7(495)268-04-70

Казахстан +7(7172)727-132

Киргизия +996(312)96-26-47

<https://comeup.nt-rt.ru/> || [cpb@nt-rt.ru](mailto:cpb@nt-rt.ru)

### Installation

Before using the winch, make sure all electrical components have no corrosion or damaged; the environment should be clear and dry.

#### ► Mounting

- It is very important that the winch will be mounted on a flat and hard surface of mounting channel in order to make sure the motor, drum and gearbox housing are aligned correctly.
- The wire rope shall be wound in an under-wound orientation only.
- Four (4) M10 x 1.50 pitch 8.8 grade w/44 N-m torque setting (maximum) high tensile steel bolts must be used in order to sustain the loads imposed on the winch mounting.
- Two (2) M12 x 1.75 pitch 8.8 grade w/76 N-m torque setting (maximum) high tensile steel bolts must be used for fastening the roller fairlead into the mounting channel.
- It is always preferred to use both tie bars in the final installed configuration.
- If there is a rope pileup on one end of the drum, reverse the winch to relieve the load and move your anchor point further to the centre of the vehicle. Then you can rewind for a neat layer of the rope.

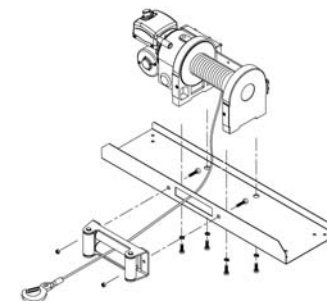

#### ► Wiring Diagram

Attach the black lead firmly to the negative (-) battery terminal and red lead to the positive (+) battery terminal. The voltage drop for the winch motor must not exceed 10% of the nominal voltage of 12/24V.

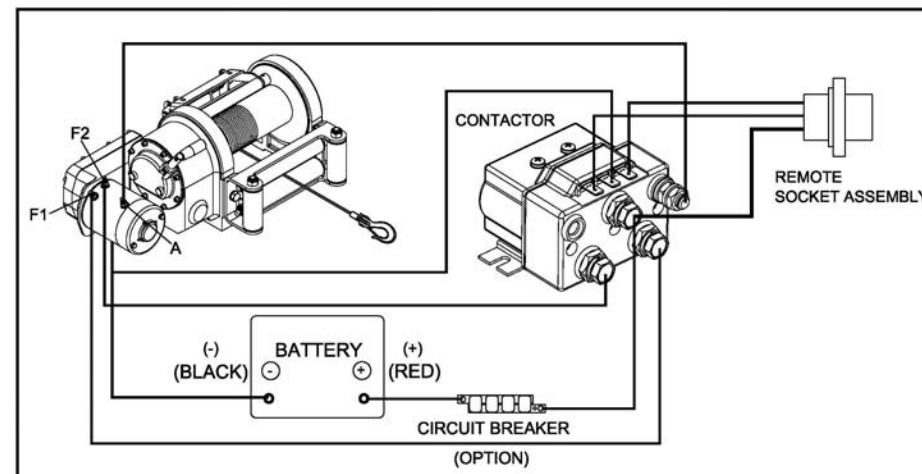

## Warning

- The winch is not intended to be used in any manner for the movement or lifting of personnel.
- The rated line pull shown is based on the first layer of rope on the drum for the winch only. Consult the wire rope manufacturer for wire rope rating.
- The rope winding on the drum shall remain 5 wraps from the drum.

## Parts List

Item No.	Description	Part No.	Qty
1	Motor 12V	881778	1
	Motor 24V	882469	
2	Bearing kit	880323	1
3	Gearbox base kit	880324	1
4	2 <sup>nd</sup> gear kit	880325	1
5	1 <sup>st</sup> shaft kit	880355	1
6	2 <sup>nd</sup> shaft	880327	1
7	1 <sup>st</sup> gear kit	880356	1
8	Gearbox upper base	880329	1
9	Thrust bearing kit	880330	1
10	Worm kit	880331	1
11	Thrust bearing kit	880332	1
12	Needle bearing kit	880333	1
13	Gear box	880334	1
14	Drum kit	880357	1
15	Support rack	880336	1
16	Worm wheel kit	880337	1
17	Output shaft kit	880338	1
18	Gearbox rear cover	880339	1
19	Control box 12V	880340	1
	Control box 24V	880341	
20	Grounding lead	880009	1
21	Wire rope w/hook	880106	1
	Wire rope w/hook for PN:784598	882479	
22	Cable tensioner	880358	1
23	Tie bar kit	880359	1
24	Roller fairlead	880023	1
25	Remote control	880025	1
26	Mounting hardware	880343	1
27	Handsaver strap	880026	1

Алматы (7273)495-231  
 Ангарск (3955)60-70-56  
 Архангельск (8182)63-90-72  
 Астрахань (8512)99-46-04  
 Барнаул (3852)73-04-60  
 Белгород (4722)40-23-64  
 Благовещенск (4162)22-76-07  
 Брянск (4832)59-03-52  
 Владивосток (423)249-28-31  
 Владикавказ (8672)28-90-48  
 Владимир (4922)49-43-18  
 Волгоград (844)278-03-48  
 Вологда (8172)26-41-59  
 Воронеж (473)204-51-73  
 Екатеринбург (343)384-55-89

Иваново (4932)77-34-06  
 Ижевск (3412)26-03-58  
 Иркутск (395)279-98-46  
 Казань (843)206-01-48  
 Калининград (4012)72-03-81  
 Калуга (4842)92-22-67  
 Кемерово (3842)65-04-62  
 Киров (8332)68-02-04  
 Коломна (4966)23-41-49  
 Кострома (4942)77-07-48  
 Краснодар (861)203-40-90  
 Красноярск (391)204-63-61  
 Курск (4712)71-13-04  
 Курган (3522)50-90-47  
 Липецк (4742)52-20-81

Магнитогорск (3519)55-03-13  
 Москва (495)268-04-70  
 Мурманск (8152)59-64-93  
 Набережные Челны (8552)20-53-41  
 Нижний Новгород (831)429-08-12  
 Новокузнецк (3843)20-46-81  
 Ноябрьск (3496)41-32-12  
 Новосибирск (383)227-86-73  
 Омск (3812)21-46-40  
 Орел (4862)44-53-42  
 Ростов (862)225-72-31  
 Оренбург (3532)37-68-04  
 Пенза (8412)22-31-16  
 Красноярск (391)204-63-61  
 Петрозаводск (8142)55-98-37  
 Псков (8112)59-10-37  
 Пермь (342)205-81-47

Ростов-на-Дону (863)308-18-15  
 Рязань (4912)46-61-64  
 Самара (846)206-03-16  
 Санкт-Петербург (812)309-46-40  
 Саратов (845)249-38-78  
 Севастополь (8692)22-31-93  
 Саранск (8342)22-96-24  
 Симферополь (3652)67-13-56  
 Смоленск (4812)29-41-54  
 Сочи (862)225-72-31  
 Ставрополь (8652)20-65-13  
 Сургут (3462)77-98-35  
 Сыктывкар (8212)25-95-17  
 Тамбов (4752)50-40-97  
 Тверь (4822)63-31-35

Тольятти (8482)63-91-07  
 Томск (3822)98-41-53  
 Тула (4872)33-79-87  
 Тюмень (3452)66-21-18  
 Ульяновск (8422)24-23-59  
 Улан-Удэ (3012)59-97-51  
 Уфа (347)229-48-12  
 Хабаровск (4212)92-98-04  
 Чебоксары (8352)28-53-07  
 Челябинск (351)202-03-61  
 Череповец (8202)49-02-64  
 Чита (3022)38-34-83  
 Якутск (4112)23-90-97  
 Ярославль (4852)69-52-93

Россия +7(495)268-04-70

Казахстан +7(7172)727-132

Киргизия +996(312)96-26-47

<https://comeup.nt-rt.ru/> || [cpb@nt-rt.ru](mailto:cpb@nt-rt.ru)

## Winch Assembly

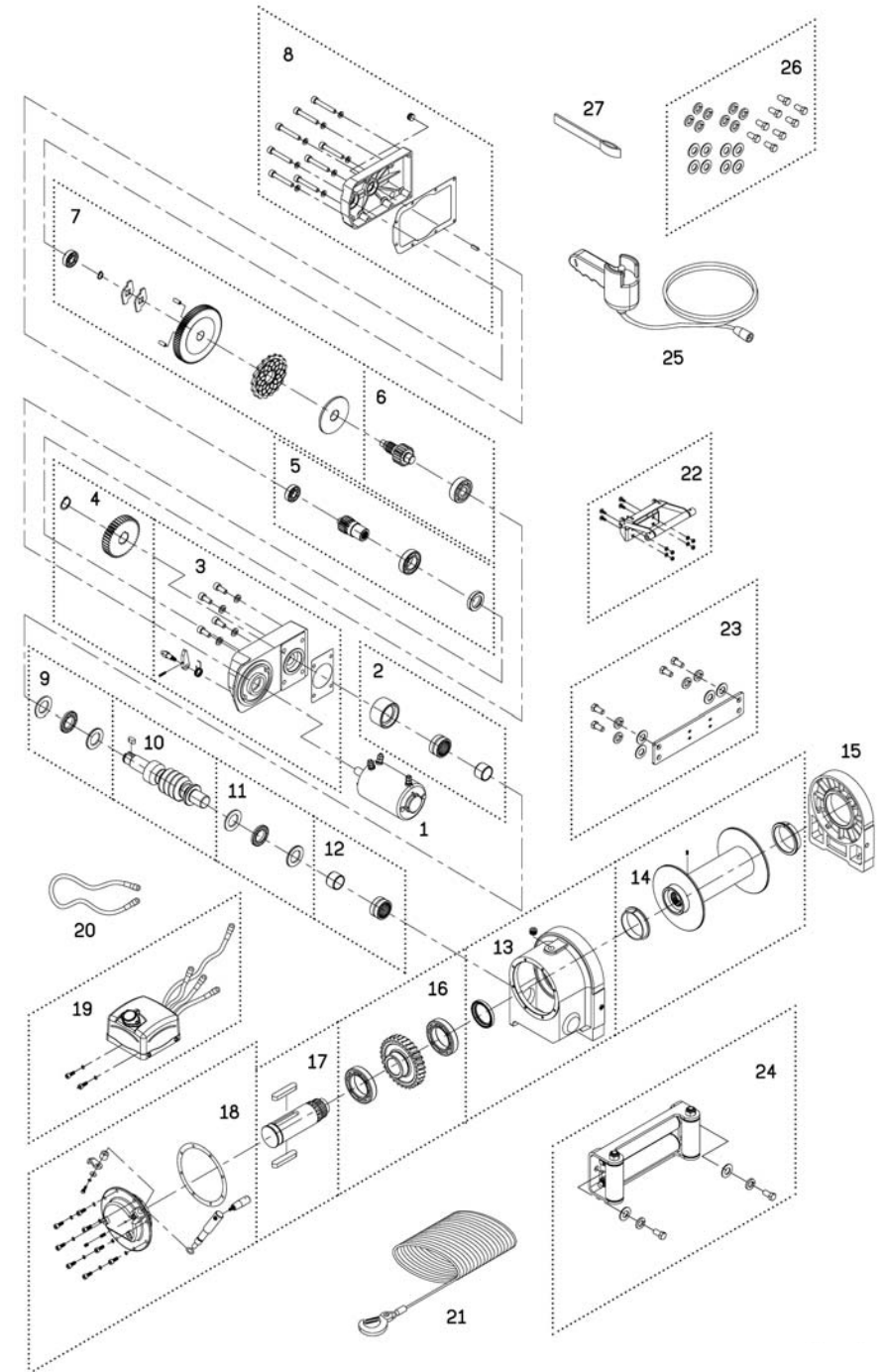

2020/12/21 Ver:9